

**VONDOM®**



WE ARE VONDOM	02
DESIGNERS DISEÑADORES	06
COLLECTIONS COLECCIONES	
STONES	15
VELA	21
BONES	39
BYE-BYE	45
FAZ	49
PASTA KANELLONI	69
PASTA SPAGUETTI	73
ALMA	77
REST	83
MOMA	95
BLANCA	107
MORA	111
VASES	115
PILLOW	125
VERTEX	131
DOUX	139
SURF	145
PAL	149
LAVA	153
VLEK	157
CHEMISTUBES	161
FIESTA	165
PROJECTS & EVENTS PROYECTOS Y EVENTOS	171
INSTRUCTIONS & RECOMENDATIONS INSTRUCCIONES Y RECOMENDACIONES	181
FEATURES, COLOURS & FINISHED CARACTERÍSTICAS, COLORES Y ACABADOS	
DIMENSIONS DIMENSIONES	195

# DESIGNERS DISEÑADORES



## KARIM RASHID

USA (\*1960)

He is one of the most prolific designers of his generation. Over 3000 designs in production, over 300 awards and projects in over 35 countries. Projects for Umbra, Deutsche Bank, Audi, Method, Dirt Devil, Artemide, Magis, Citibank, Hyundai, LaCie, Samsung, Veuve Clicquot, Swarovski...

Karim's work is featured in 20 permanent collections and he exhibits art in galleries worldwide.

Karim is a perennial winner of the Red Dot Award, Chicago Athenaeum Good Design Award, I.D. Magazine Annual Design Review and IDSA Industrial Design Excellence Award.

Karim's has been featured in magazine and books including Time, Financial Times, NY Times, Esquire, GQ, and countless more.

In 2009 Rizzoli released Karim's latest monograph KarimSpace, featuring 36 of Karim's interior architecture designs. Other books include Karim's guide to living, "Design Your Self" (Harper Collins, 2006), "Digipop", a digital exploration of computer graphics (Taschen, 2005), compact portfolio published by Chronicle Books (2004), as well as two monographs titled "Evolution" (Universe, 2004) and "I Want to Change the World" (Rizzoli, 2001).

Es uno de los diseñadores más prolíficos de su generación. Más de 3000 diseños en producción, más de 300 premios y trabajos en más de 35 países.

Trabajos diseñados para empresas como Umbra, Deutsche Bank, Audi, Method, Dirt Devil, Artemide, Magis, Citibank, Hyundai, LaCie, Samsung, Veuve Clicquot, Swarovski...

Su obra está representada en 20 permanentes colecciones expuestas en galerías de arte internacionales.

Karim es un ganador perenne del Red Dot Award, Chicago Athenaeum Good Design Award, I.D. Magazine Annual Design Review y IDSA Industrial Design Excellence Award.

También ha aparecido en varias publicaciones como las de Time, Financial Times, NY Times, Esquire, GQ, y muchas más.

En 2009 Rizzoli sacó la última monografía de Karim

- KarimSpace - representando 36 de sus diseños interiores. Otros libros incluyen la guía de vivir de Karim, "Design Your Self"(Harper Collins, 2006); "Digipop", una exploración digital del ordenador gráfico (Taschen, 2005); portafolio compacto publicado por Chronicle Books (2004); así como dos monografías tituladas "Evolution" (Universe, 2004) y "I Want to Change the World" (Rizzoli, 2001).

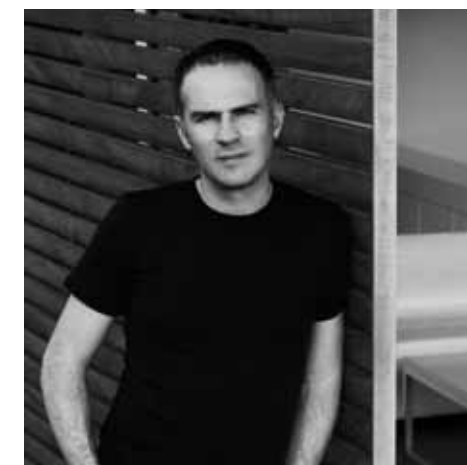

## RAMON ESTEVE

Valencia, Spain (\*1964)

Ramón Esteve is an architect by the Superior Technical School of Madrid since 1990.

Harmony, serenity and essentiality are some of the constant that appear in his work and that announce his will of contributing much more than building to the environment. The result is the generation of environments with an encircling atmosphere, that cause unique experiences.

His portfolio includes extensive experience in public projects: sanitary, educational and cultural; private buildings for public use: offices, bank, playful, interior design of hotels, restaurants, shops or installations of ephemeral architecture. Mention aside deserves his work in the field of the exclusive houses, where his philosophy is shown in his true magnitude. In the area of product design, at present collaborates with well known prestige brands such as Vondom, Vibia, Joquer or Gandia Blasco.

Professor of the Architecture School of University Politécnica of Valencia since 2005. Habitually gives workshops and conferences above architecture and design. He has received numerous prizes by his work as the architect and designer.

He has published two monographs: RAMON ESTEVE. DESDE LA ARQUITECTURA, by the way of the monographic exposition in which took place the Valencia Institute of Modern Art IVAM in the summer of 2010 and RAMON ESTEVE ARCHITECTURE / DESIGN, published by Loft Publications and distributed in 35 countries.

Ramón Esteve es arquitecto por la Escuela Técnica Superior de Madrid desde 1990.

Armonía, serenidad y esencialidad son algunas de las constantes que aparecen en su obra y que anuncian la voluntad del que quiere aportar al entorno mucho más que edificios. El resultado es la generación de entornos con una atmósfera envolvente, que provocan experiencias únicas.

Su portfolio incluye extensa experiencia en obra pública: sanitaria, docente y cultural, edificios privados de uso público: oficinas, bancarios, lúdicos, interiorismo de hoteles, restaurantes, locales comerciales o instalaciones de arquitectura efímera. Mención aparte merece su obra en el campo de las viviendas unifamiliares exclusivas, donde su filosofía se muestra en su verdadera magnitud. En el área del diseño de producto, actualmente colabora con marcas de reconocido prestigio como Vondom, Vibia, Joquer o Gandia Blasco.

Profesor en la Escuela de Arquitectura de la Universitat Politécnica de Valencia desde 2005, habitualmente imparte workshops, talleres y conferencias sobre arquitectura y diseño. Ha recibido durante su trayectoria numerosos premios por su trabajo como arquitecto y diseñador.

Tiene publicadas dos monografías: RAMON ESTEVE. DESDE LA ARQUITECTURA, a propósito de la exposición monográfica que tuvo lugar en el Instituto Valenciano de Arte Moderno IVAM en el verano de 2010 y RAMON ESTEVE ARCHITECTURE / DESIGN, editado por Loft Publications y distribuido en 35 países.



## JAVIER MARISCAL

### Valencia, Spain (\*1950)

Javier Mariscal is, First and foremost, an image creator who develops his work using all kinds of supports and disciplines. Furniture design, painting, sculpture, illustrations, interior design, graphic design, landscaping, gardening and so on, are all the objects of his professional, vital activity.

He has recently done the interior design and graphics for; the Uno Design collection contract for the 11th floor of the Hotel Puerta América Madrid, Silken Hotels Group; the graphic image for the 32nd edition of the America's Cup; the new brand image for Camper for Kids; The Bombay Sapphire Design Exhibition on 20th century design objects, and the visual identity for the British post-production company "Framestore".

Among other projects, he is currently working on; a retrospective exhibition at the Design Museum of London which will take place in the spring on a full-length cartoon with Fernando Trueba; on three books about his artistic and design work; and on pieces of furniture for VONDOM, UNO DESIGN and MAGIS.

He has collaborated with companies such as Memphis, Akaba, Bidasoa, BD Ediciones de Diseño, Moroso, Nani Marquina, Vorwerk, Equipaje, Amat, Alessi, Sangetsu, Magis, Cosmic, Amat3, Santa&Cole, Lalique and Phaidon.

Javier Mariscal es ante todo un creador de imágenes que desarrolla su trabajo en todo tipo de soportes y disciplinas.

El diseño de mobiliario, la pintura, la escultura, la ilustración, el interiorismo, el diseño gráfico, el paisajismo, la jardinería... son objeto de su actividad profesional y vital. Recientemente, ha diseñado la planta 11 del Hotel Puerta América del grupo de Hoteles Silken, la imagen gráfica de la 32 Edición de la America's Cup, la nueva marca Camper For Kids, la exposición The Bombay Sapphire Design Exhibition sobre Objetos de Diseño del Siglo XX y la identidad visual de la empresa británica de postproducción Framestore.

Actualmente está trabajando, entre otros proyectos, en el Hotel 550 Wellington en Toronto (Canadá), en la imagen de la próxima edición de la America's Cup, en la película de animación dirigida por Fernando Trueba y en una colección de mobiliario para VONDOM, UNO DESIGN y MAGIS.

Ha colaborado con empresas como Memphis, Akaba, Bidasoa, BD Ediciones de Diseño, Moroso, Nani Marquina, Vorwerk, Equipaje, Amat, Alessi, Sangetsu, Magis, Cosmic, Amat3, Santa&Cole, Lalique y Phaidon.

Mariscal se expresa a través de un lenguaje personal, para seguir haciendo cosquillas a los ojos que miran su obra y crear complicidad con el otro.



## A-CERO

### Joaquín Torres, Spain (\*1969) Rafael Llamazares, Spain (\*1970)

A-cero Joaquín Torres architects, is a company of architects, established in 1996 and whose activity focuses on the complete development of architectural projects.

The human team, led by Joaquín Torres and his partner Rafael Llamazares, has been growing throughout the past years and sums up to more than 60 professionals spread throughout different offices, Spain (1), UAE Dubai (1), Dominican Republic (1); currently working on projects of different magnitudes. "Our working method is based on a detailed analysis of the client's needs and the projects program; we imagine, project and persuade".

"The key to our success is that we stick to the initial idea throughout the whole process".

During their professional trajectory they have maintained collaborations with construction companies and developers, taking part in contests or carrying out consultancy work with other architect and engineering studios, developing projects in common, as well as working with lawyers offices helping in management and town-planning.

A-cero Joaquín Torres architects es una sociedad creada en 1996 cuya actividad se centra en el desarrollo integral de proyectos de arquitectura.

El equipo humano, dirigido por Joaquín Torres y ayudado por su socio Rafael Llamazares, ha ido creciendo desde entonces hasta reunir a más de 60 profesionales, repartidos entre las sedes de España (2), Emiratos Árabes, Dubai (1) y Republica Dominicana (1), trabajando en la actualidad en proyectos de diferente envergadura.

"Nuestro método de trabajo parte del estudio profundo del programa de necesidades del cliente; imaginamos, proyectamos y persuadimos.

La clave de nuestro trabajo está en mantener el hilo conductor de la idea a lo largo de todo el proceso.

En nuestra trayectoria profesional hemos mantenido colaboraciones con empresas constructoras y promotoras presentándonos a concursos o realizando labores de consultoría, con otros estudios de arquitectura e ingeniería desarrollando conjuntamente proyectos, y con bufetes de abogados, colaborando en temas de gestión y planeamiento urbanístico.



## STEFANO GIOVANNONI & ELISA GARGAN

### La Spezia, Italy (\*1960)

Stefano Giovannoni, architect, industrial and interior designer, born in La Spezia, lives and works in Milan. He collaborates with companies including Alessi, BM, Deborah, Fiat, Flos, Henkel, Inda, Laufen, Magis, Normann Copenhagen, Oras, Oregon Scientific, Seiko, Siemens, 3M, Voismart, etc.

He has designed a number of products which have met with great commercial success, including, for Alessi, Girotondo and Mami, plastic products, the Bagno Alessi and the "Bombo" range for Magis. Winner of numerous prizes and competitions, his works are part of the permanent archives of the Georges Pompidou Centre and the collections of the MOMA in New York.

Elisa Gargan Giovannoni, born in Pordenone, industrial and interior designer, is Stefano's partner and wife, collaborates as a designer with Giovannoni Design and other companies including Alessi, Magis, Millefiori, Bisazza, Veneta Cucine, Bertazzoni, Marzorati&Ronchetti, Viceversa. Winner of numerous prizes and competitions, she runs courses at the Domus Academy and the Polytechnic School of Design.

Stefano Giovannoni, arquitecto, diseñador industrial y de interiores, nacido en La Spezia, vive y trabaja en Milán.

Colabora con empresas como Alessi, BM, Deborah, Fiat, Flos, Henkel, Inda, Laufen, Magis, Normann Copenhagen, Oras, Oregon Scientific, Seiko, Siemens, 3M, Voismart, etc.

Ha diseñado una gran serie de productos con gran éxito comercial, incluso, para Alessi, Girotondo y Mami, productos de plástico, el Bagno Alessi y el "Bombo" para Magis. Ganador de numerosos premios y concursos, sus trabajos forman parte de los archivos permanentes de Georges Pompidou Centro y de las colecciones de MOMA de Nueva York.

Elisa Gargan Giovannoni, nació en Pordenone, diseñadora industrial y de interiores, es socia y esposa de Stefano, colabora como diseñadora en los diseños de Giovannoni Design y otras empresas como Alessi, Magis, Millefiori, Bisazza, Veneta Cucine, Bertazzoni, Marzorati y Ronchetti, Viceversa. Ganadora de numerosos premios y concursos. Imparte cursos en la Academia Domus y la Escuela Politécnica de Diseño.



## LUDOVICA+ ROBERTO PALOMBA

### Roberto Palomba, Italy (\*1963) Ludovica Serafini, Italy (\*1961)

Ludovica + Roberto Palomba, architect and designer, founders Palomba Serafini Associati, in Milan.

Ludovica + Roberto Palomba's work has always been rich of cultural references. Their projects are derived from observations of change in human behavior. Their mission is to generate products that merge function, innovation and longevity - intimate and emotional connections that last. "We believe that good design already exist in a sort of collective unconsciousness and our task is to mold and deliver them. A truly successful piece of design must feel fresh but not unfamiliar when it is discovered."

The equation of their work is hence summed up in one singular concept: Evident Design.

Ludovica + Roberto Palomba, arquitecto y diseñador, son los fundadores de Palomba Serafini Associati, en Milán.

El trabajo de Ludovica + Roberto Palomba siempre ha sido rico en referencias culturales. Sus proyectos se derivan de las observaciones del cambio en la cultura humana. Su misión es generar productos que fusionan función, innovación y longevidad, conexiones íntimas y emocionales que duran. "Nosotros creemos que el buen diseño existe en un tipo de inconsciencia colectiva y nuestra tarea es adaptarlo y entregarlo. Un buen diseño debe sentir fresca pero no familiar cuando sea descubierto."

La ecuación de su trabajo se resume en un concepto singular: Un diseño evidente.



## TERESA SAPEY

Cuneo, Italy (\*1962)

Contemporary Architect, after her graduation in Facoltà d'Architettura (Architectural Faculty) of the Politecnico di Torino, completed her studies in Bfa Doctorado en Bellas Artes (Doctorate in fine arts) from the Parson's School of Design de París, studying UPA6 in the Architecture University "La Villete" in Paris and collaborate with the designers Alberto Pinto and Jacques García; in 1990 she moved to Madrid. After further small collaborations with the architect Rafael de la Hoz, she founded her own studio "Teresa Sapey Arquitectura" specializing in vanguard design for luxury houses, shops, restaurants, parking and hotels, along with industrial design.

She designs energy spaces for different sectors. Her projects are based on the emotions and feelings; the objective is producing results that belong to the same users' emotions of the space.

Nowadays, she is teaching in the Universidad Camilo José Cela (plastic literature). Moreover she also collaborates as a lecturer in Master Interior Design in the Universidad Politécnica de Madrid, and is a member of RIBA ("Royal Institute British Architect").

She participates in conferences in Carleton University Ottawa, Mc Gil University Montreal, University of Waterloo and Cambridge.

Arquitecta contemporánea, después de graduarse en la Facoltà d'Architettura del Politecnico di Torino, completar sus estudios con Bfa Doctorado en Bellas Artes en la Parson's School of Design de París, estudiar UPA6 en la Facultad de Arquitectura "La Villete" de París y colaborar con los diseñadores Alberto Pinto y Jaques García; en 1990, toma la decisión de instalarse en Madrid. Tras una breve colaboración con el arquitecto Rafael de la Hoz, funda su estudio propio "Teresa Sapey Arquitectura" especializándose en el diseño de vanguardia de lujo para casas, tiendas, restaurantes, parkings y hoteles, así como diseño industrial. Encabezó una serie de masteres en la "Domus Academy" en Milán. Diseña espacios energicos para diferentes sectores. Sus proyectos se basan en las emociones y los sentimientos; el objetivo es producir los resultados que transportan estas mismas emociones a los usuarios del espacio.

Actualmente es profesora en la Universidad Camilo José Cela (curso de narrativa plástica). Además colabora como conferenciante en el Máster de Diseño Interior de la Universidad Politécnica de Madrid y es miembro de la RIBA ("Royal Institute British Architect").

Participa en conferencias en Carleton University Ottawa, Mc Gil University Montreal, University of Waterloo y Cambridge.



## ARCHIRIVOLTO DESIGN

Claudio Dondoli, Italy (\*1954)

Marco Pucci, Italy (\*1953)

Archirivolto was founded in 1983 by Claudio Dondoli and Marco Pucci as an industrial planning, design and architecture studio.

While studying Architecture in Florence, Claudio and Marco and some friends put up an experimental theatre group.

When they decided to focus their joint efforts on design, consolidating their ties of friendship, their interest in theatre strongly influenced the setup of their new studio, drenched in creativity, sense of reality, respect and attention for that public.

Keen on gaining an insight into the world of production and the market, they started off managing an interior decoration shop.

For Archirivolto "design is beauty, harmony and freedom and cannot therefore be bound by strict, pre-established rules, nor can it be the privilege of a social or cultural elite.

The designer is committed to creating beauty for everyone and to make design approachable for an ever-increasing number of people.

Archirivolto fue fundado por Claudio Dondoli y Marco Pucci en 1983 como estudio de proyección industrial, diseño y arquitectura.

Claudio y Marco, durante sus estudios de Arquitectura en Florencia, crean con algunos amigos un grupo de experimentación teatral. Cuando, continuando con la asociación eligen ocuparse juntos de diseño, el interés por el teatro influencia de modo determinante la preparación del nuevo estudio: creatividad, sentido de la realidad, respeto y atención por el público.

Interesados en comprender desde dentro el mundo de la producción y el mercado, comienzan abriendo un negocio de decoración.

Para Archirivolto "el diseño significa belleza, armonía y libertad; no puede vincularse a reglas fijas ya establecidas, ni ser privilegio de una élite social o cultural.

El diseñador tiene el deber de crear una belleza para todos y acercar el diseño a un número de personas siempre mayor.



## JMFERRERO

Valencia, Spain (\*1978)

estudi{H}ac is a creative company founded in 2003 by Jose Manuel Ferrero, where made-to-measure works are realized for visionary clients who bet for new creative solutions with value of brand, without closing the channel of communication between the equipment of design and the company.

In her specialized equipments of work believe themselves where they all contribute creative, innovative and different solutions to obtain a project that exceeds the expectations and initial results of success for that the client waits.

Our projects answer to an elegance Bespoke, are retailers and expressive, combine textures and made-to-measure materials to wake unexpected emotions up. estudi{H}ac as an Atelier of design.

This experience and professionalism has led them to working with companies like Toyota Japan, Vondom, Porcelanosa, Puntmobles, Sancal, Samoa, Cell lighting, Trades Valencia, Hayashi Telemu Japan, Do+ce, Manterol, Gandia Blasco ...

Prestige awards, special mentions, The more recent is the Best of Year awards that grants the American Interior magazine Design and the award the best designer Industrial who grants the Valencia magazine Trends.

estudi{H}ac es una empresa creativa fundada en el 2003 por Jose Manuel Ferrero, donde se realizan trabajos a medida para clientes visionarios que apuestan por nuevas soluciones creativas con valor de marca, sin cerrar el canal de comunicación entre el equipo de diseño y la empresa.

En ella se crean equipos especializados de trabajo donde todos aportan soluciones creativas, innovadoras y diferentes para conseguir un proyecto que sobrepase las expectativas y resultados iniciales de éxito que el cliente espera.

Nuestros proyectos responden a una elegancia Bespoke, son detallistas y expresivos, combinan texturas y materiales a medida para despertar emociones inesperadas. El cual se concibe como un atelier de diseño.

Su trayectoria, experiencia y profesionalidad les ha llevado a trabajar con empresas como Toyota Japón, Vondom, Porcelanosa, Puntmobles, Sancal, Samoa, Celda iluminación, Feria Valencia, Hayashi Telemu Japón, Do+ce, Manterol, Gandia Blasco...

Ganar prestigios premios, menciones especiales, el mas reciente es el Best of Year awards que otorga la revista americana Interior Design y premio al mejor diseñador Industrial que otorga la revista Valenciana Tendencias.



## HARRY&CAMILA

Harry Van, Netherland (\*1966)

Camila Vega, Cuba (\*1971)

Known for their mysterious objects, exemplars of vibrant design of the 21st century. The futuristic shapes are reminiscent of technologies applied to high speed, the imaginary of HARRY&CAMILA drawing on aeronautical performances, with fantasies of aircraft wings, space travel and -ships.

Their resulting design approach concentrates on experimentation with materials and topologies. HARRY is from the Netherlands, class 1966, industrial designer with a degree from the Design Academy Eindhoven. CAMILA Chilean nationality grew up in Mexico, degree in fashion design, Istituto Marangoni Milan.

They met during their Master at the Domus Academy in Milan 1994. In 1988 they established studio HARRY&CAMILA in Milan. In 2002 HARRY&CAMILA moved to Barcelona but continue to spend time in their adopted home Italy, working with a number of design manufactures. A good mix between the Dutch free spirit and Latin sensualism. They work across a wide range of disciplines signing for clients worldwide a.o Alessi, Dedon, Fontana Arte, JLindeberg+Puma, Living Divani, Rosenthal studio-Line. Harry&camila have exhibited extensively around the world and won several awards including in 2007, 2008, 2009 & 2010 the GOOD DESIGN Award of the Chicago Athenaeum, the world's oldest and most prestigious award of its kind.

Conocidos por sus misteriosos objetos, ejemplo de diseño vibrante del siglo XXI. Las formas futuristas son una reminiscencia de las tecnologías aplicadas a la alta velocidad, la imaginación de Harry & Camila en las actuaciones aeronáuticas, con fantasías de alas de aviones, viajes espaciales y naves.

El resultado de sus diseños se centra en la experimentación con materiales y topologías. Harry es de los Países Bajos, 1966, es diseñador industrial por la Academia de Diseño de Eindhoven. CAMILA de nacionalidad chilena creció en México y es titulada en diseño de moda, por el Instituto Marangoni de Milán.

Se conocieron durante su especialización en la Academia Domus de Milán en 1994. En 1988 establecieron el estudio Harry & Camila, en Milán. En 2002 Harry & Camila se trasladaron a Barcelona, pero hoy en día continúan disfrutando de su casa en Italia, trabajando con un gran número de productos de diseño manufacturados. Una buena mezcla entre el espíritu Holandés libre y la sensualidad latina. Ellos trabajan en una amplia gama de disciplinas con firmas de todo el mundo Alessi ao, Dedon, Fontana Arte, JLindeberg + Puma, Living Divani, Rosenthal Studio-Line. Harry & Camila han realizado numerosas exposiciones en todo el mundo y han ganado varios premios en 2007, 2008, 2009 y 2010 donde se les concedió el premio GOOD DESIGN del Chicago Athenaeum, el premio más antiguo y prestigioso del mundo en este ámbito.

COLLEC  
TIONS COLEC  
CIONES

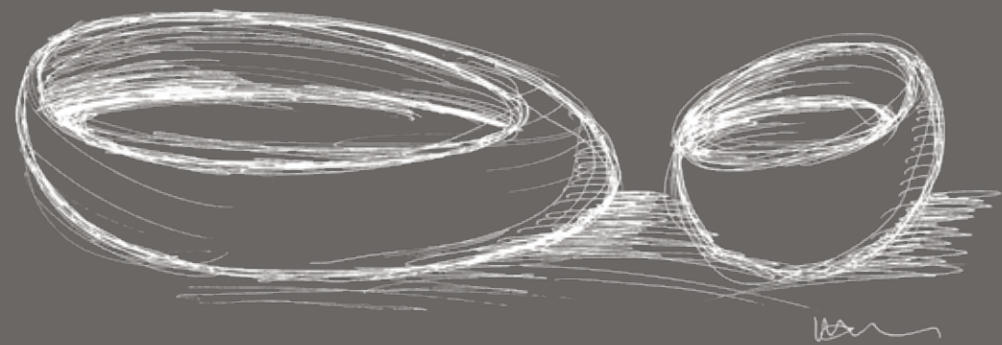

# STONE COLLEC TION

designed by Stefano Giovannoni & Elisa Gargan

"It seeks to be integrated as an element that we can find in the nature"

"Pretende integrarse como un elemento que se encuentre en la naturaleza"

# STONE COLLECTION

As the name suggests, was to develop elements we can find in nature creating a synergy between the natural and the artificial landscape. The material, as well as it's original shape permit Stone integrate perfectly into every environment and transmit the elegance.

Su propio nombre lo indica, Stone, pretende integrarse como un elemento que podemos encontrar en la naturaleza, creándose una sinergia entre el paisaje natural y el artificial. El material, como la forma que adquiere, permite que se integre a la perfección en cualquier entorno, transmitiendo elegancia.

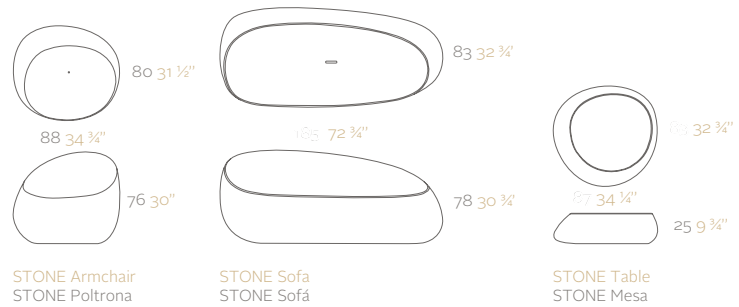

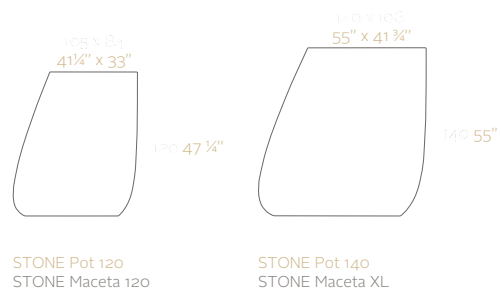
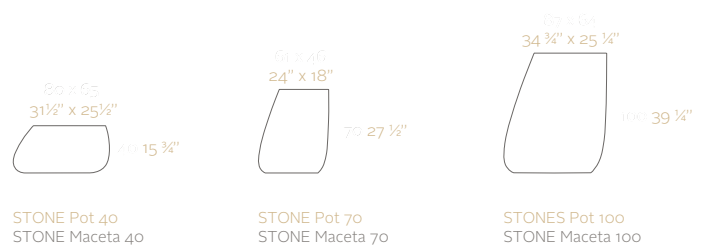



# VELA COLLEC TION

designed by Ramon Esteve

“Looks for offer the comfort and the quality of the interior furniture without losing its characteristic of origin”

“Busca ofrecer el confort y la calidez de los muebles de interior sin perder sus cualidades de origen”



VELA is a modulate system with a prismatic geometry elementary that bases its singularity in the balance of its proportions. The elements can combine among themselves to be able to integrate in any space. Their flat volumes seem to float to some centimetres of the floor and when they are illuminated they are transformed into light architectures.

Es un sistema modular con una geometría elemental prismática que basa su singularidad en el equilibrio de sus proporciones. Los elementos se pueden combinar entre sí para poder convivir en cualquier espacio. Sus volúmenes rotundos parecen flotar a unos centímetros del suelo y cuando se iluminan se transforman en arquitecturas livianas.



VELA Table Sun Chaise  
VELA Mesa Tumbona

VELA Sun Chaise  
VELA Tumbona



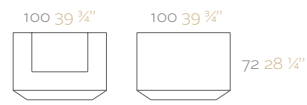

VELA Lounge Chair  
VELA Butaca

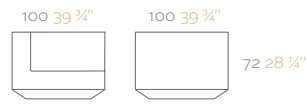

VELA Sofa Corner Unit  
VELA Sofá Módulo Esquina

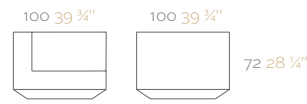

VELA Sofa Right Unit  
VELA Sofá módulo Derecho

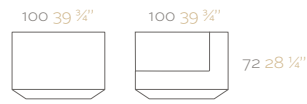

VELA Sofa Left Unit  
VELA Sofá módulo Izquierdo

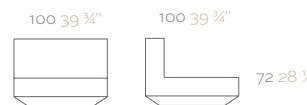

VELA Sofa Central Unit  
VELA Sofá Módulo Central



VELA Sofa Central Unit XL  
VELA Sofá Módulo Central XL

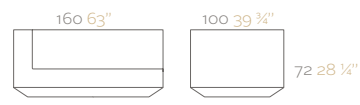

VELA Sofa Right Unit Chaiselonge  
VELA Sofá Módulo Derecho Chaiselonge



VELA Sofa Left Unit Chaiselonge  
VELA Sofá Módulo Izquierdo Chaiselonge



VELA Sofa Table  
VELA Mesa Sofá



VELA Sofa Table  
VELA Mesa Sofá

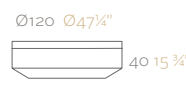

VELA Puff Chaiselonge  
VELA Puff Chaiselonge

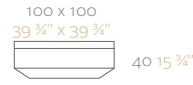

VELA Puff Chaise-longue  
VELA Puff Chaise-longue

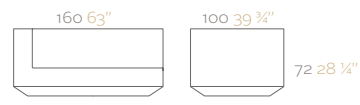

VELA Sofa Right Unit XL  
VELA Sofá Módulo Derecho XL

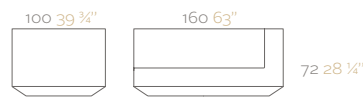

VELA Sofa Left Unit XL  
VELA Sofá Módulo Izquierdo XL

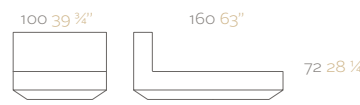

VELA Sofa Chaiselongue Unit  
VELA Sofá Módulo Chaiselongue

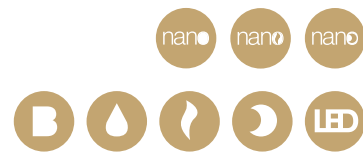



30 11 3/4" 30 11 3/4"  
72 28 1/4"  
VELA Bar Stool  
VELA Taburete

50 19 3/4" 50 19 3/4"  
100 39 3/4"  
VELA High Table  
VELA Mesa Alta



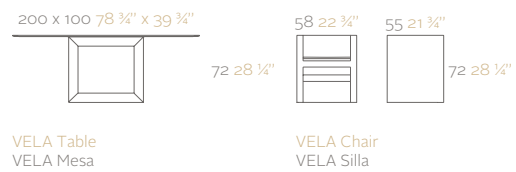
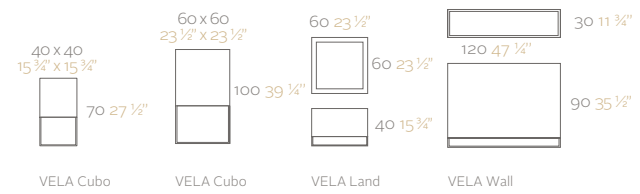

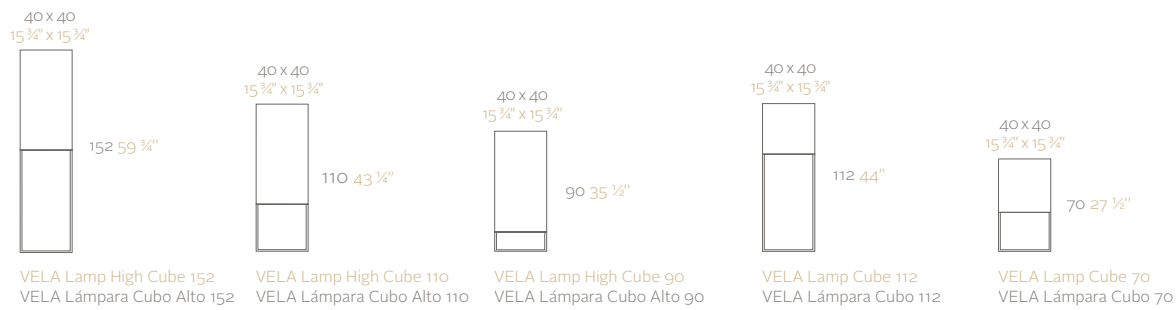





40 x 40  
15 3/4" x 15 3/4"



VELA Chill Table 40  
VELA Chill Mesa 40

60 x 60  
23 1/2" x 23 1/2"



VELA Chill Table 60  
VELA Chill Mesa 60

80 x 80  
31 1/2" x 31 1/2"



VELA Chill Table 80  
VELA Chill Mesa 80

40 x 40  
15 3/4" x 15 3/4"



VELA Chill Puff 40  
VELA Chill Puff 40

60 x 60  
23 1/2" x 23 1/2"



VELA Chill Puff 60  
VELA Chill Puff 60

80 x 80  
31 1/2" x 31 1/2"



VELA Chill Puff 80  
VELA Chill Puff 80

100 x 100  
39 3/4" x 39 3/4"



VELA Chill Table 100  
VELA Chill Mesa 100

Ø120 Ø47 1/4"



VELA Chill Table Ø120  
VELA Chill Mesa Ø120

40 x 40  
15 3/4" x 15 3/4"



VELA Chill Pot  
VELA Chill Maceta

100 x 100  
39 3/4" x 39 3/4"



VELA Chill Puff 100  
VELA Chill Puff 100

Ø120 Ø47 1/4"



VELA Chill Puff Ø120  
VELA Chill Puff Ø120

40 x 40  
15 3/4" x 15 3/4"



VELA Chill Lamp  
VELA Chill Lámpara

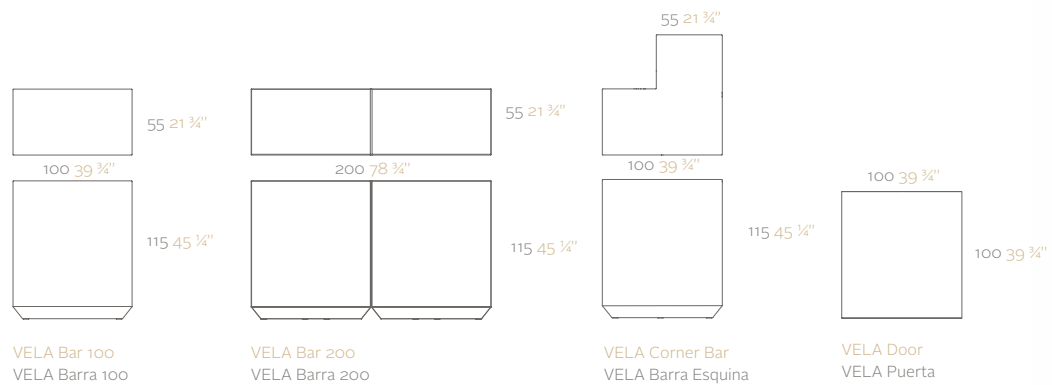
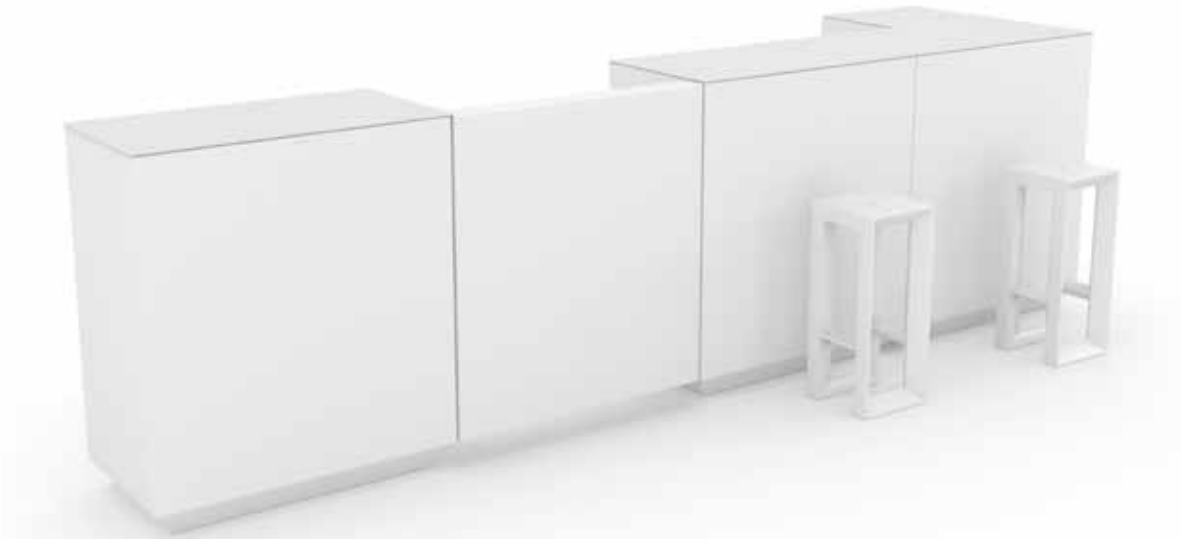

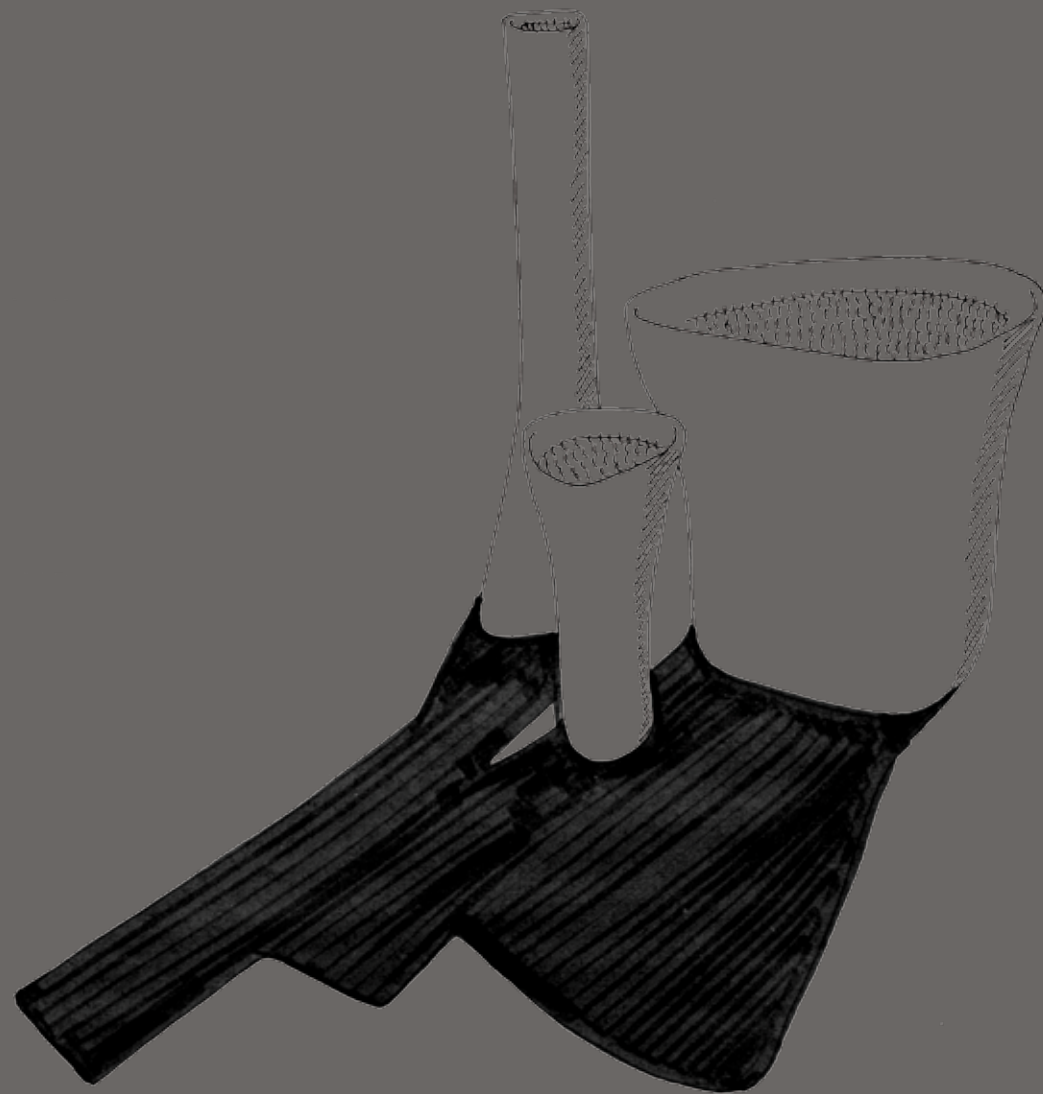

# BONES

COLLEC  
TION

designed by Ludovica+Roberto Palomba

“Elegant by its slimness but at the same time strong by its conception”

“Elegante por su esbeltez pero a la vez robusta por su concepción”

# BONES

COLLEC  
TION

Bones is the new and elegant collection of flowerpots. Its generous volume is alleviated for a subtle edge that makes it light.

Bones is reversible; it is to say can be planted with the wide part or to use that part as base whenever the greater stability to be needed or by aesthetics.

Has an invisible internal structure provides the necessary strength transmitting the weight from the base to the base of the flowerpot for achieve to support the weight of any plant or tree.

Bones es la nueva y elegante colección de maceteros. Su generoso volumen es aliviado por un sutil reborde que la hace ligera.

Bones es reversible, es decir, puede ser plantada con el borde ancho en la parte posterior o utilizar ese borde como base para cuando se necesite mayor estabilidad o simplemente por estética.

Tiene una estructura interna invisible a la vista que proporciona la robustez necesaria para lograr soportar el peso de cualquier planta o árbol.

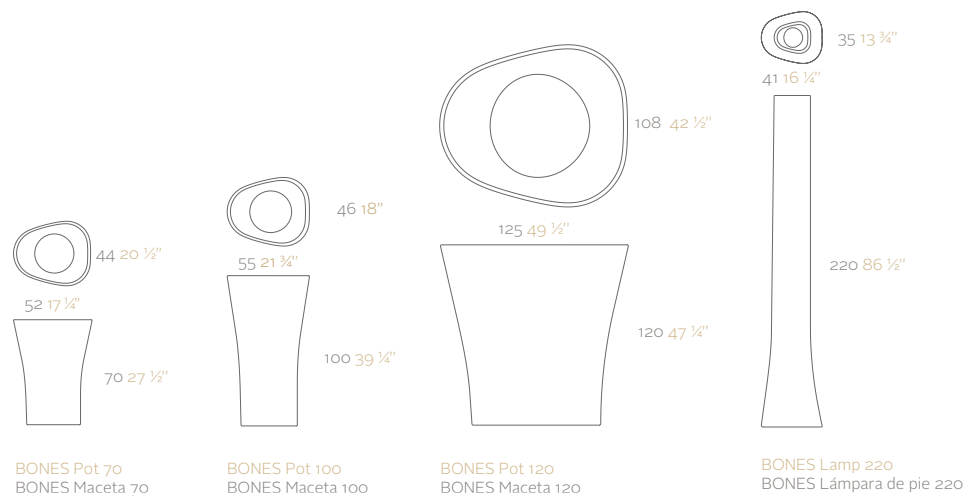

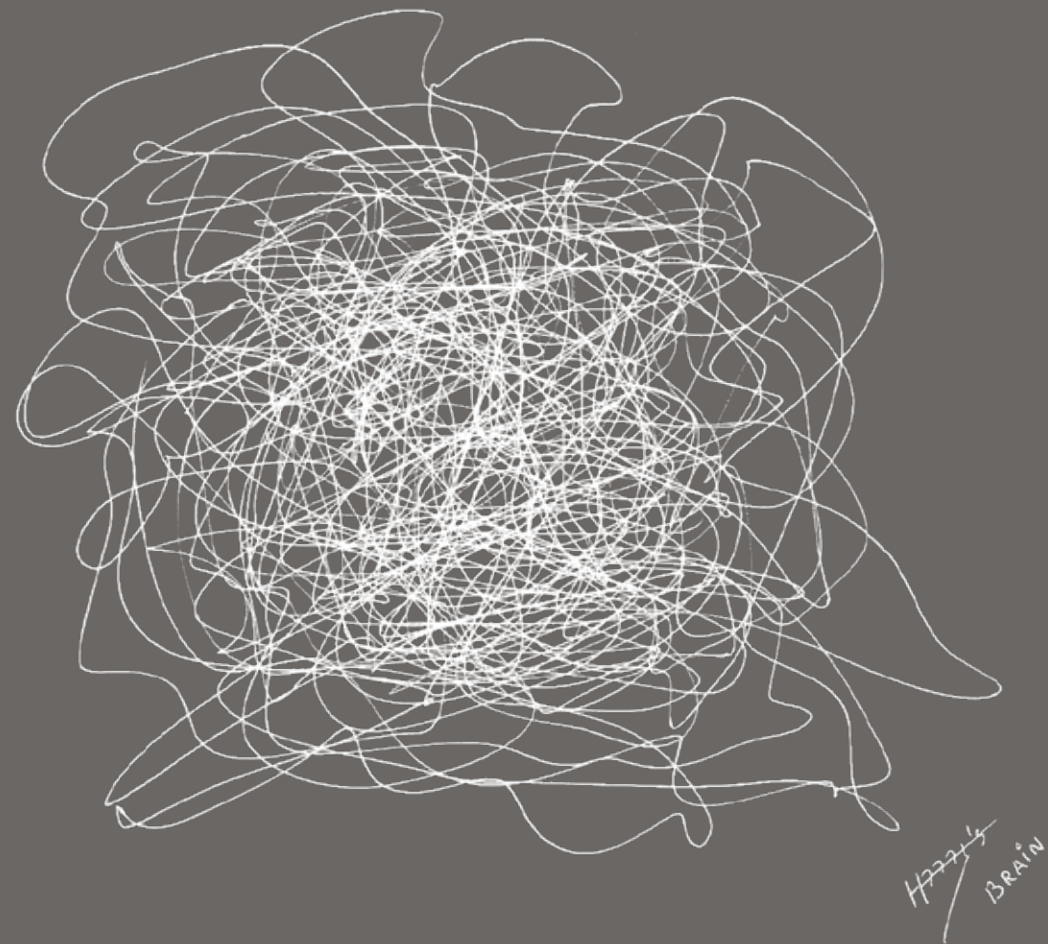

# BYE-BYE COLLECTION

designed by Harry&Camila

"It's hardbored in this contrast between simultaneous unity and inner conflict"

"Está en este contraste entre la unidad simultánea y el conflicto interior"

# BYE-BYE COLLECTION

The artistic couple's intention for this new collection: Two completely different shapes -an abstract greeting figure at the upper edge and sole geometric at the lower edge- appear side-by-side but never seem to touch each other, thus creating additional interest. A vertical running line turns the object into an entity in its own right, as if by magic. Its perspective extruded cartoon like space appearance symbolizes travelling at the speed of light.

The fascination of Bye-Bye is harbored in this contrast between simultaneous unity and inner conflict.

La intención de la pareja artística para esta nueva colección: Dos formas completamente diferentes - una figura abstracta en el borde superior y en el borde geométrico inferior fluye de lado al lado pero al mismo tiempo parece que nunca se toque uno al otro, creando así un interés adicional. Una línea vertical corriente gira el objeto en una entidad propia, como si por magia. Su perspectiva de dibujo animado estirado como apariencia de espacio simboliza viajes en la velocidad de la luz.

La fascinación de Bye-Bye está en este contraste entre unidad simultánea y conflicto interior.

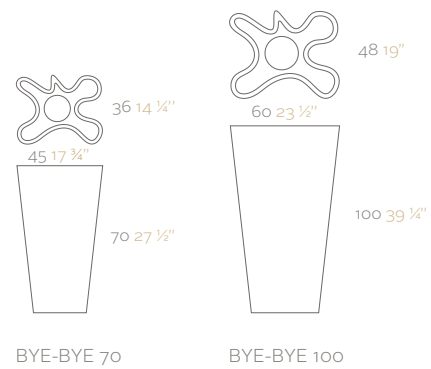



FAZ  
COLLEC  
TION

designed by Ramon Esteve

“FAZ lines arise from mineral crystallization; of its capricious play with light, surrounding us in a suggestive atmosphere of reflexes”

“Las líneas de FAZ nacen de la cristalización mineral, de su juego caprichoso con la luz, que nos envuelve en una sugerente atmósfera de reflejos desdibujados”





FAZ lines arise from mineral crystallization; of its capricious play with light, surrounding us in a suggestive atmosphere of reflexes. The attractive movements of the lights and shadows generate a feeling of rhythmic and organic order, a refreshing illusion that enraptures a dream world of new realities.

Las líneas de FAZ nacen de la cristalización mineral, de su juego caprichoso con la luz, que nos envuelve en una sugerente atmósfera de reflejos desdibujados. A partir de los atractivos movimientos de luces y sombras se genera la sensación de orden rítmico y orgánico, una ilusión refrescante que transporta a un mundo onírico de nuevas realidades.

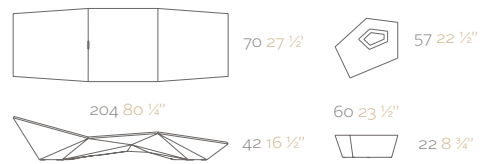

FAZ Sun Chaise  
FAZ Tumbona

FAZ Sun Chaise Table  
FAZ Mesa Tumbona



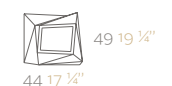

49 19 1/4"  
44 17 1/4"



110 39 1/4"

FAZ High Pot  
FAZ Maceteros Alta



55 21 3/4"

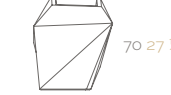

66 25"

FAZ Medium Pot  
FAZ Maceteros Media



45 17 3/4"



57 22 3/4"



42 16 1/2"

FAZ Down Pot  
FAZ Maceteros Baja



68 26 3/4"



61 24"

160 62 1/2"

FAZ High Pot XL  
FAZ Maceta Alta XL



92 36 1/4"



77 30 1/4"

101 39 3/4"

FAZ Medium Pot XL  
FAZ Maceta Media XL



63 24 3/4"



82 32 1/4"

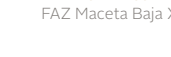

60 23 1/2"

FAZ Down Pot XL  
FAZ Maceta Baja XL

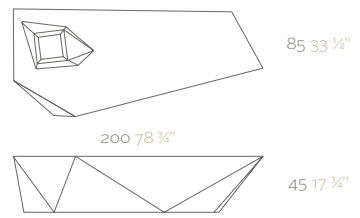
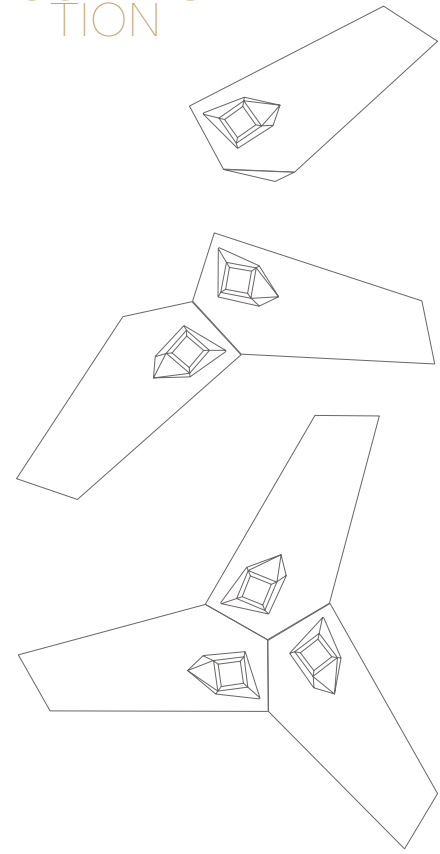

FAZ Bench  
FAZ Banco



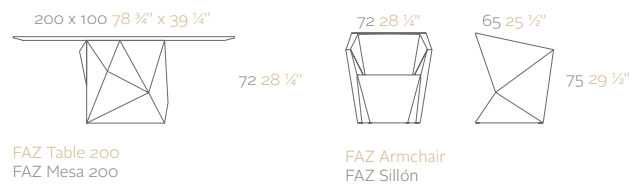



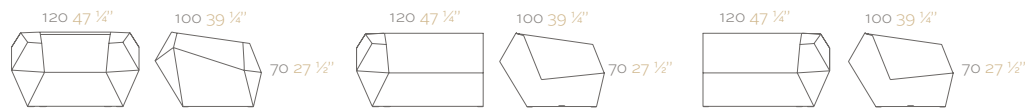

FAZ Lounge Chair  
FAZ Butaca

FAZ Sofa Right Unit  
FAZ Sofá Módulo Derecho

FAZ Sofa Left Unit  
FAZ Sofá Módulo Izquierdo

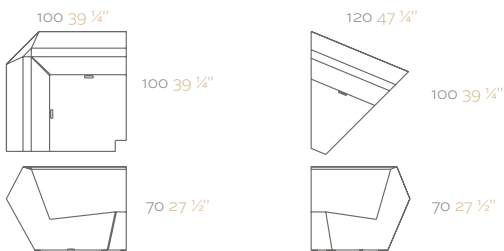

FAZ Sofa Corner 90° Unit  
FAZ Sofá Módulo Esquina 90°

FAZ Sofa Corner 45° Unit  
FAZ Sofá Módulo Esquina 45°



FAZ Sofa Central Unit  
FAZ Sofá Módulo Central



FAZ Sofa Chaiselongue  
FAZ Sofa Chaise-longue

FAZ Table Sofa  
FAZ Mesa Sofá





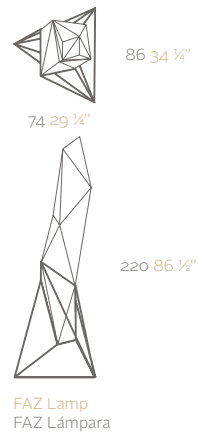
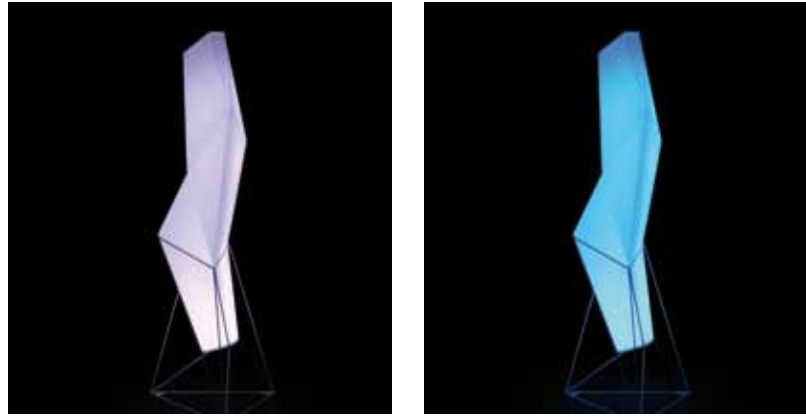



PASTA  
COLLECTION  
KANELLONI

designed by Karim Rashid

“Its necessary to focus on a form that would fit the most modern of spaces ”

“Es necesario enfocarse en una forma más apta a los espacios modernos”

# PASTA

## COLLECTION KANELLONI

The KANNELLONI planters have a minimal design and a pure geometric form that is versatile in its placement. While designing the KANNELLONI family Karim found it necessary to focus on a form that would fit the most modern of spaces, it could sit on a window sill, wall or step, and still be a commercial product that could be specified widely in the contract market. So you can take KANNELLONI and stuff it with soil, and have a beautiful garden in your home, office, or by the pool.

Los maceteros KANNELLONI tienen un diseño minimalista y una pura forma geométrica versátil.

Al diseñar la familia KANNELLONI, Karim descubrió que es necesario enfocarse en una forma más apta a los espacios modernos, podría utilizarse en una repisa de ventana, pared o pasillo, y todavía podría ser un producto especificado extensamente en el mercado del contract. Entonces se puede llenar KANNELLONI con tierra, y tener un hermoso jardín en su hogar, la oficina, o por la piscina.

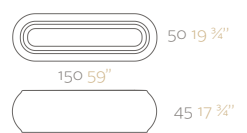

KANNELLONI Pot 120  
KANNELLONI Maceta 120



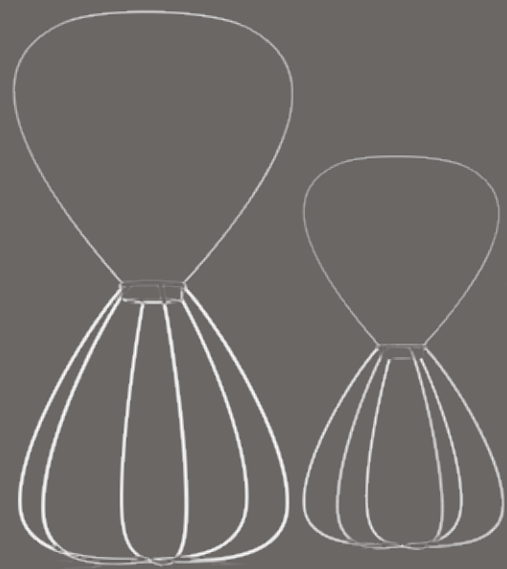

PASTA  
COLLECTION  
SPAGHETTI

designed by Karim Rashid

“Monumentalize the plant, to raise it from the ground”

“Monumentalizar la planta, alzarla del suelo”

# PASTA

## COLLECTION SPAGUETTI

The SPAGHETTI planters evoke a lightness and duality that speak of the combination of materials.

The idea is to monumentalize the plant, to raise it from the ground, to have less mass using a skeleton support that suspends the volume in space.

El macetero KANNELLONI evoca ligereza y dualidad ya que habla de la combinación de materiales.

La idea es monumentalizar la planta, alzarla del suelo para aligerarla mediante un ligero soporte metálico que suspende el volumen en el espacio.

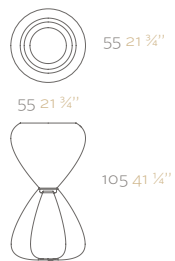

SPAGUETTI Pot Ø55  
SPAGUETTI Maceta Ø55



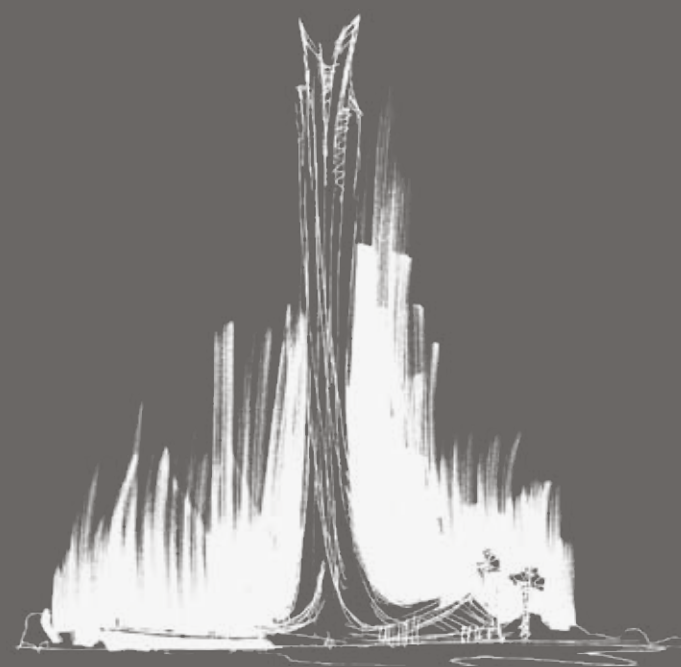

ALMA  
COLLECTION  
designed by A-cero

"Inspiring in the nature, whose stylist forms recall to the sprig of a plant..."

"Inspirada en la naturaleza, sus formas estilizadas recuerdan al tallo de una planta..."



An unique collection by its originality and innovative design inspired in nature; its shapes remind to a plant. Offers a new decoration concept keeping the usefulness for any interior space and exterior. This item can be set outside, even with the most extreme weather conditions.

Una colección única por su original e innovador diseño inspirado en la naturaleza; sus formas estilizadas recuerdan al tallo de una planta. Ofrece un nuevo concepto de decoración teniendo en cuenta el lado práctico, tanto en interior como en exterior. Este producto puede ser colocado en el exterior, incluso en condiciones climáticas extremas.

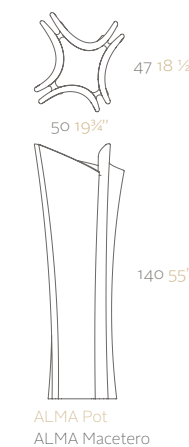



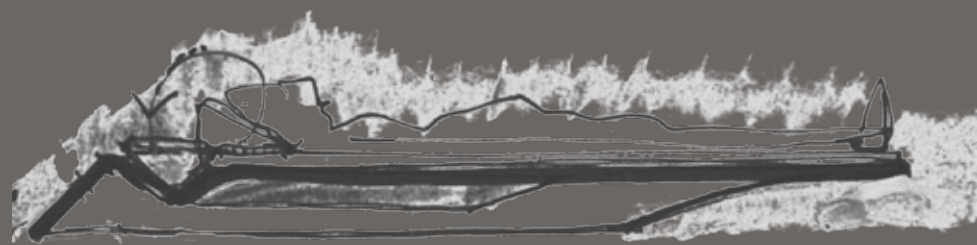

REST  
COLLEC  
TION  
designed by A-cero

“Inspiring from the Origami, Japanese arte based in the folding paper, and in the thinking line “Less is More”  
“Inspirada en el Origami, arte japonés basado en el plegado del papel, y en la línea de pensamiento “Less is more”





Simply forms, pure lines and design are the concepts that show the essence from its creators, always loyal to elegance, beauty and exclusivity.

A dynamic, light collection full with freshness that offers the maximum comfort to its users integrating in the avant-garde architecture IN&OUT.

Sencillez de formas, líneas puras y diseño son los conceptos que muestran la esencia de sus creadores, siempre fieles a la elegancia, la belleza y la exclusividad.

Una colección dinámica, ligera y llena de frescura que proporciona un máximo confort al usuario, fundiéndose en una arquitectura contemporánea IN&OUT.

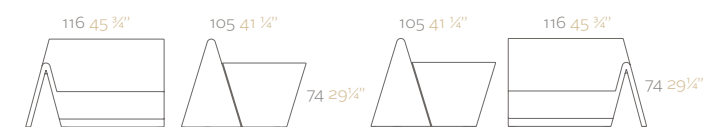

REST Sofa Right Unit  
REST Sofá Módulo Derecho

REST Sofa Left Unit  
REST Sofá Módulo Izquierdo

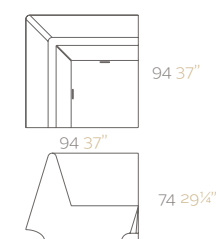

REST Sofa Corner Unit  
REST Sofá Módulo Esquina



REST Sofa Central Unit  
REST Sofá Módulo Central

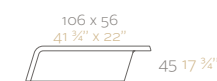

REST Chaiselongue  
REST Chaise-longue

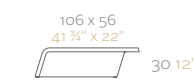

REST Chaiselongue  
REST Chaise-longue



REST  
COLLECTION

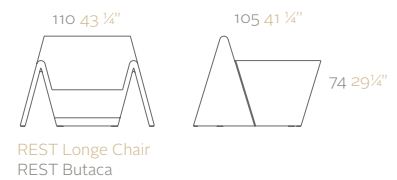

VONDOM®



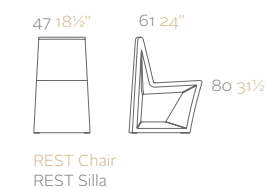
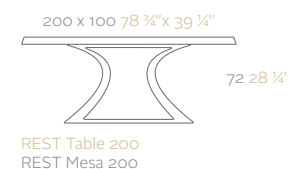
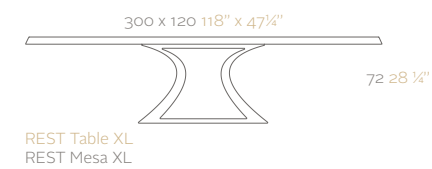

REST  
COLLECTION

VONDOM®



REST Sun Chaise  
REST Tumbona



REST Table Sun Chaise  
REST Mesa Tumbona





MOMA  
COLLECTION  
designed by Javier Mariscal

“It was decided to do a new typology of furniture unite the function of a flowerpot and an outdoor table, thus MOMA was born”

“Se decidió hacer una nueva tipología de mobiliario a partir de unir las funciones de un macetero y una mesa exterior, así nació MOMA”



# MOMA COLLECTION

It was decided to do a new typology of furniture to unite the function of a flowerpot and an outdoor table, thus MOMA was born, a collection characterizes for its versatility and originality.

The first sketches presented organic shapes that in the development of the project they were deriving toward more architectural forms that recall toe column with capital or to corbel.

Se decidió hacer una nueva tipología de mobiliario a partir de unir las funciones de un macetero y una mesa exterior, así nació MOMA, una colección caracterizada por su versatilidad y originalidad.

Los primeros bocetos presentaban formas orgánicas que en el desarrollo del proyecto fueron derivando hacia formas más arquitectónicas que recuerdan a una columna con capitel o a una ménsula.

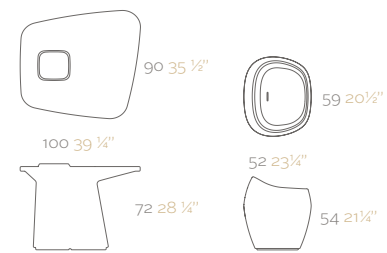

MOMA Table Medium  
MOMA Mesa Medium

MOMA Chair  
MOMA Silla

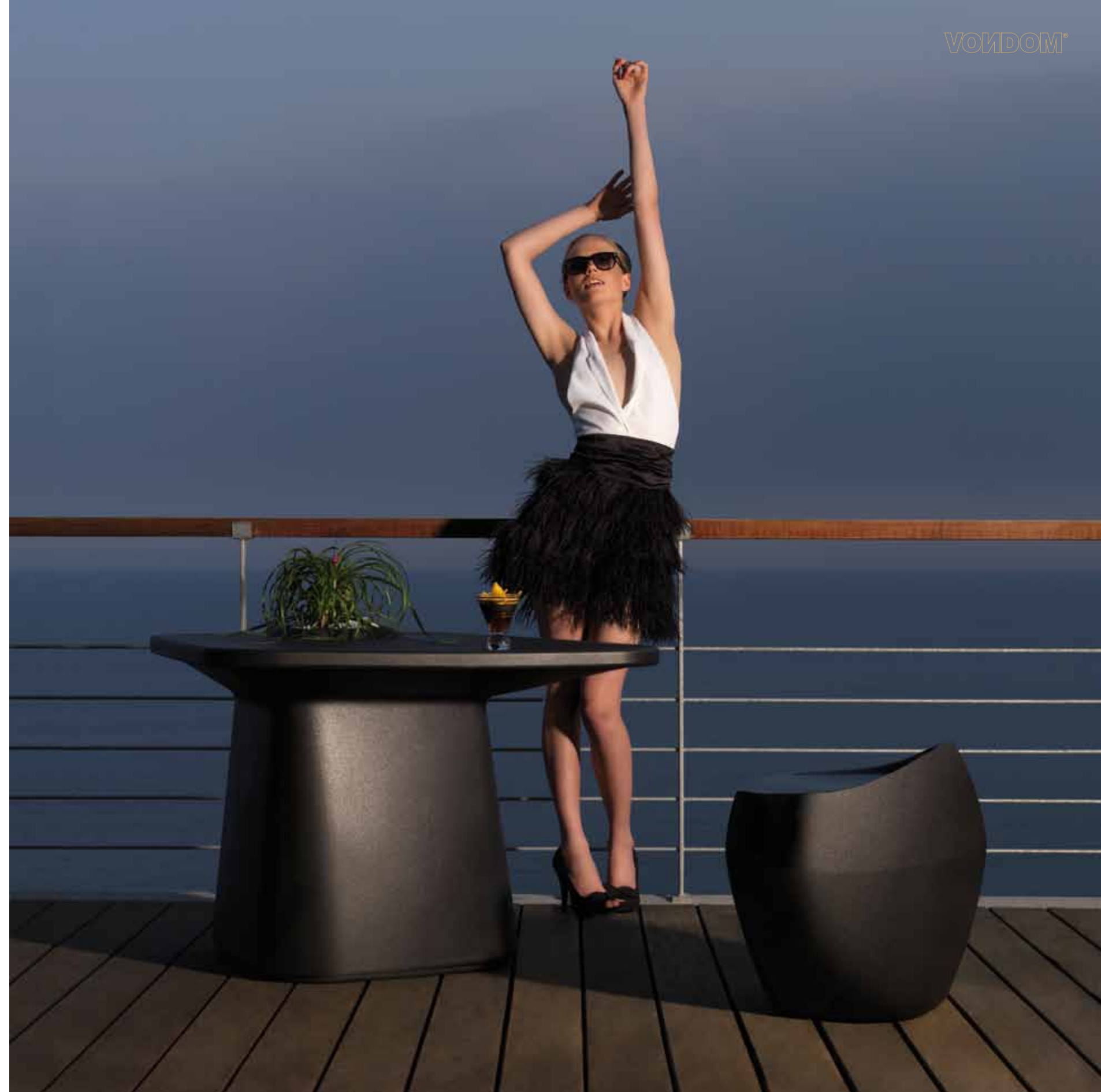

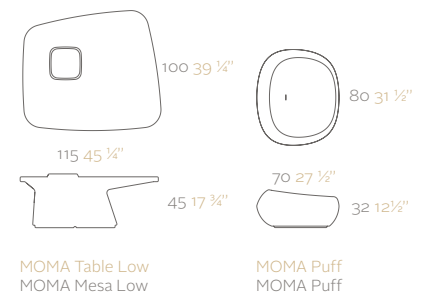

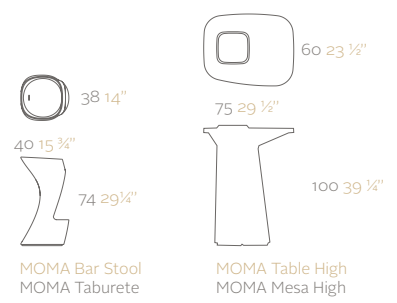

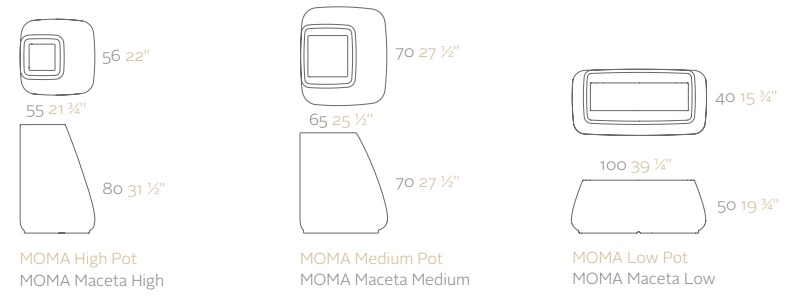

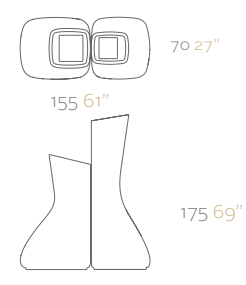

MOMA Twin Pot  
MOMA Macetas Mellizas





BLANCA  
COLLEC  
TION  
designed by Javier Mariscal

“Round, organic silhouette as a ripe fruit or a pregnant woman”

“Silueta redondeada, orgánica, como la de un fruto maduro o una mujer embarazada”

# BLANCA

COLLECTION

BLANCA adopts a form in which is recognized by the graphic language of Javier Mariscal. Its silhouette is round, organic, as a ripe fruit or a pregnant woman. BLANCA combines the language of the designer with the technology of VONDOM, giving as a result an expressive piece and of high quality.

La lámpara BLANCA adopta una forma en la que se reconoce el lenguaje gráfico de Javier Mariscal. Su silueta es redondeada, orgánica, como la de un fruto maduro o de una mujer embarazada. La lámpara BLANCA combina el lenguaje del diseñador con la tecnología de VONDOM, dando como resultado una pieza expresiva y de gran calidad.

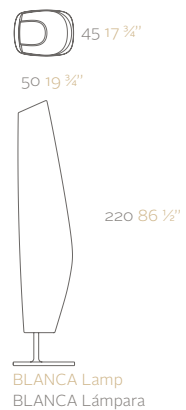

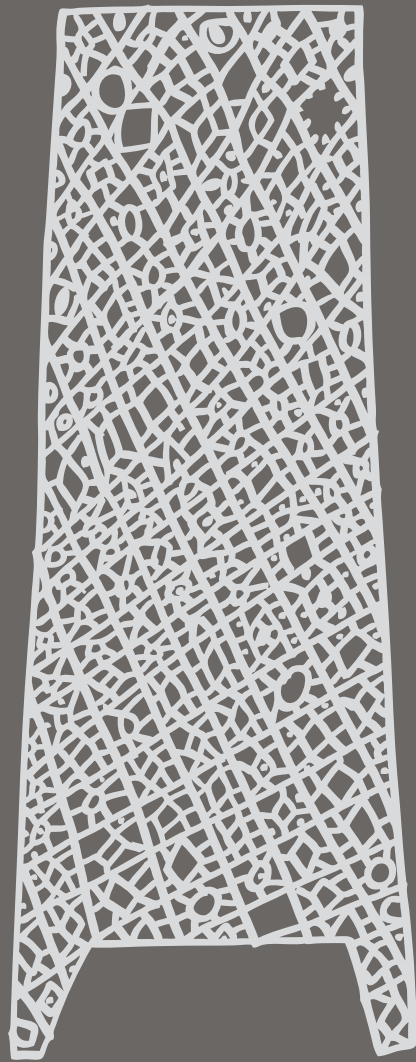

MORA  
COLLECTION  
designed by Javier Mariscal

"Inspired in the tradicional metallic punching lamps"

"Inspirada en las tradicionales lámparas metálicas troqueladas"

# MORA COLLECTION

The lighting MORA, is inspired in the traditional metallic punching lamps. The design, the functionality and the ecology are the most standing out elements of this collection. The shape has deriving toward a compact volume of pure geometry, meanwhile the texture creates a contrast with lines draws a bas-relief, drawn by Javier Mariscal, considering to offer the consumer a balanced, relaxing light with own personality.

La lámpara MORA está inspirada en las tradicionales lámparas metálicas troqueladas. El diseño, la funcionalidad y la ecología son los elementos más destacados de esta colección. La forma ha ido derivando hacia un volumen compacto de geometría pura, mientras que la textura crea un contraste en bajorrelieve, dibujada por Javier Mariscal, para ofrecer una luz relajante, equilibrada y con personalidad.

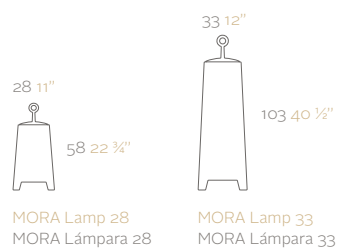
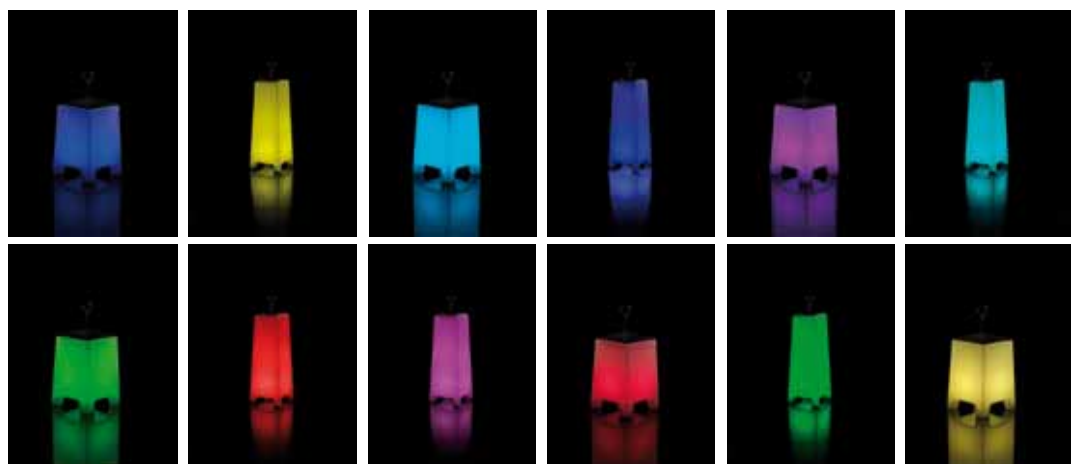



# VASES

## COLLECTION

designed by JMFerrero

"Inspired in the sculpture of the diamonds"

"Inspiradas en el tallado de los diamantes"

# VASES COLLECTION



Ø60 Ø23 1/2"

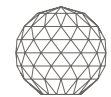

VASES Lamp 60  
VASES Lámparas 60

Ø40 Ø15 3/4"



VASES Lamp 30  
VASES Lámparas 40

Ø30 Ø11 3/4"



VASES Lamp 30  
VASES Lámparas 30

Ø68 Ø26 3/4"



220 86 3/4"

VASES High Lamp 220  
VASES Lámpara de pie 220

Ø56 Ø22"



180 70 3/4"

VASES Medium Lamp 180  
VASES Lámpara de pie 180

Ø38 Ø15"



70 27 1/2"

VASES Down Lamp 70  
VASES Lámpara de pie 70





Flowerpots, furniture and lighting which forms are inspired in the sculpture of the diamonds, obtaining some pieces of clear shapes and of great style. A collection designed to offer the consumers a modern and stylish decoration during the day, and an unique ambient during the night, creating a great visual impact that will surely draw the attention.

Maceteros, mobiliario e iluminación cuyas formas claras y de gran estilo están inspiradas en el tallado de los diamantes. Una colección pensada para ofrecer una decoración moderna y de diseño durante el día, y un ambiente único durante la noche; creando así un gran impacto visual que atrae sin duda la atención.

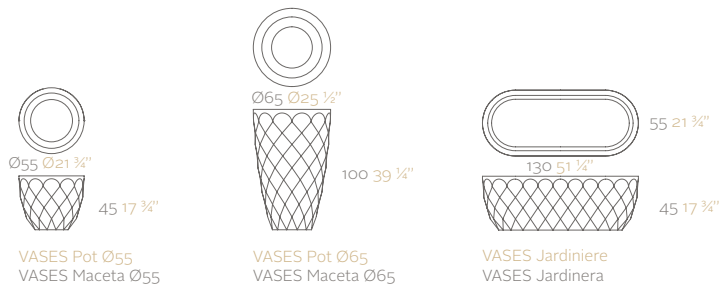
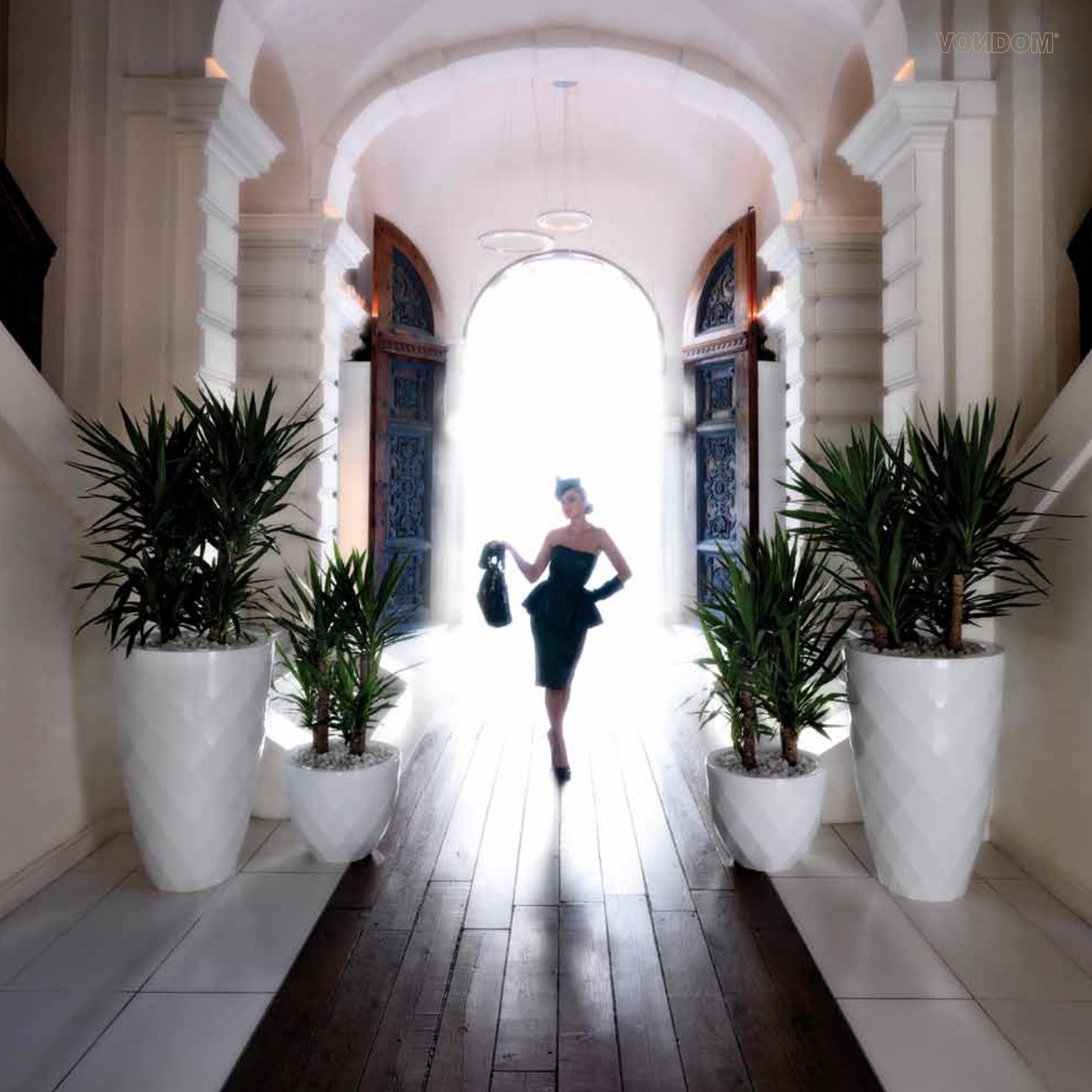



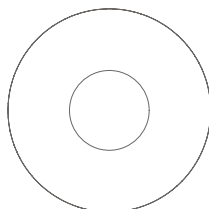

Ø178 Ø70"

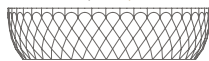

45 17 3/4"

VASES Island  
VASES Isla





PILLOW  
COLLEC  
TION

designed by Stefano Giovannoni

“A work of art that wraps you among the beauty of its shape and the needs to be live and to feel”

“Una obra de arte que te envuelve entre la belleza de sus formas y la necesidad de vivir y sentir”

A mix among coolness, exquisiteness, sophistication and comfort; that evokes an exclusive environment of relaxation and serenity. A work of art that wraps you among the beauty of its shape and the needs to be live and to feel.

Una aleación entre frescura, exquisitez, sofisticación y comodidad; que evoca un ambiente exclusivo de relax y serenidad. Una obra de arte que te envuelve entre la belleza de sus formas y la necesidad de vivir y sentir.





82 x 94 3/4" x 37"



75 29 1/2"

PILLOW Armchair  
PILLOW Butaca

67 x 67  
26 1/2" x 26 1/2"



20 7 3/4"

PILLOW Table  
PILLOW Mesa

67 x 67  
26 1/2" x 26 1/2"



35 13 3/4"

PILLOW Puff  
PILLOW Puff

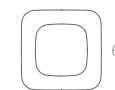

67 26 1/2"

67 26 1/2"



35 13 3/4"

PILLOW Pot  
PILLOW Maceta



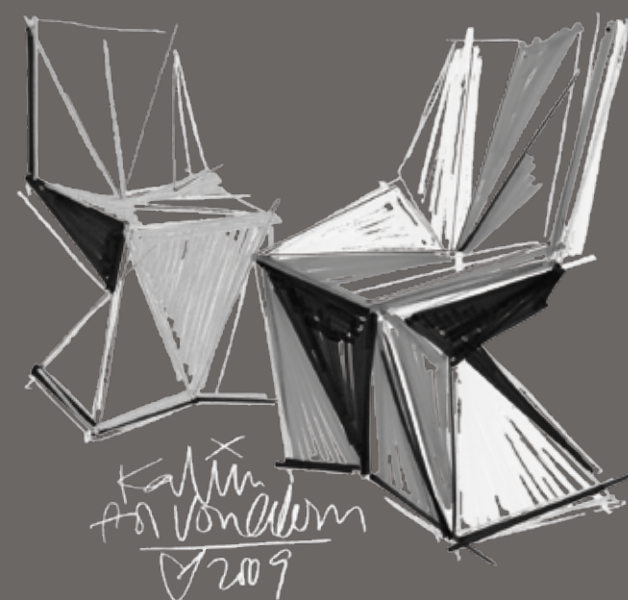

# VERTEX COLLEC TION

designed by Karim Rashid

"Triangular planes meet dynamically to create comfortable forms suitable"

"Planos triangulares que se unen dinámicamente para crear formas confortables"







Set of tables and chair for IN&OUT, its triangular planes meet dynamically to create comfortable forms suitable. The collection VEXTEX is created for integrating into our space a more conceptual architectural piece, to give it a more sophisticated touch.

Conjunto de mesas y silla para IN&OUT, cuyos planos triangulares se unen dinámicamente para crear formas confortables que se adaptan al cuerpo.

La colección VEXTEX ha sido creada para integrar en nuestro espacio un producto arquitectónico aportando un toque más sofisticado.

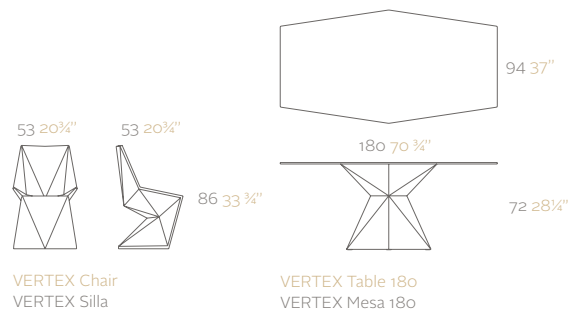

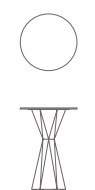

72 28¼"

VERTEX Round Table  
VERTEX Mesa Redonda  
Ø50 Ø19 ¾"  
Ø60 Ø23 ½"  
Ø70 Ø27 ½"  
Ø80 Ø31 ½"  
Ø90 Ø35 ½"  
Ø120 Ø47 ¼"



72 28¼"

VERTEX Square Table  
VERTEX Mesa Cuadrada  
Ø50 Ø19 ¾"  
Ø60 Ø23 ½"  
Ø70 Ø27 ½"  
Ø80 Ø31 ½"  
Ø90 Ø35 ½"

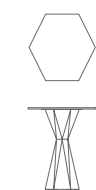

72 28¼"

VERTEX Hexagonal Table  
VERTEX Mesa Hexagonal  
Ø60 Ø23 ½"  
Ø70 Ø27 ½"  
Ø80 Ø31 ½"  
Ø90 Ø35 ½"  
Ø120 Ø47 ¼"

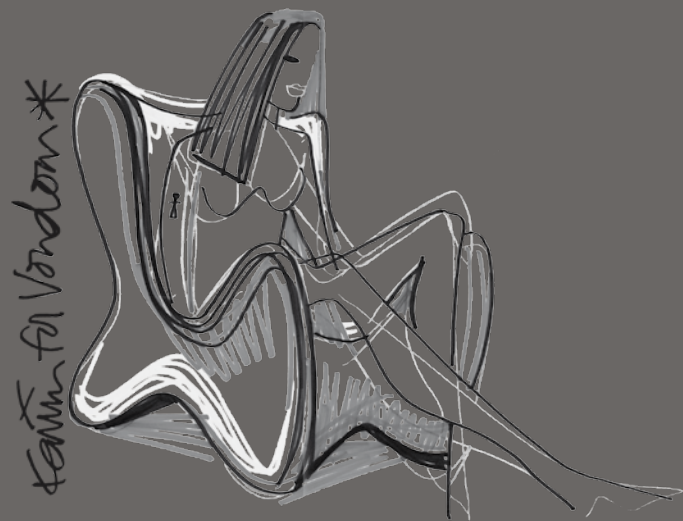

# DOUX

## COLLEC TION

designed by Karim Rashid

“DOUX, a collection of different pieces derives directly from the pen sketching freely: organic, spontaneous, friendly, and colourful. The zoomorphic forms are to engage, to touch, to sit, to enjoy”

“DOUX, una colección orgánica, espontánea, colorida...formas naturales pensadas para tocar, sentarse, disfrutar; extraídas directamente de sus bocetos”



The versatility & dynamism are the most standing out elements of this collection. One of the peculiarity of this product family is the multi-functionality of the table - when laying down, it carries out the function as table and there has a hole works as room for storage; when raising up, the hole used as flower pot or as a cool ice-tray for champagne or wines etc.

La versatilidad y dinamismo son las cualidades más destacables de esta colección. Una de las peculiaridades de esta familia de productos es la multi-funcionalidad de la mesa -cuando está tumbada cumple la función de mesa, la cual posee un hueco para el almacenamiento de objetos; cuando está levantada, el hueco se aprovecha como macetero o como cubitera para champán, vino...

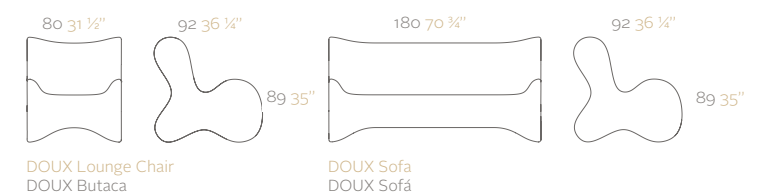



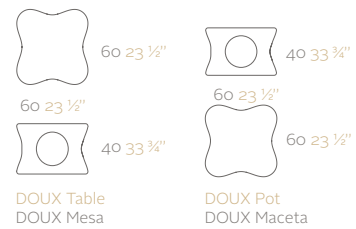



# SURF COLLEC TION

designed by Karim Rashid

"It is a soft swell in flux, a fluid gesture that changes to vary light"

"Es un suave oleaje, un gesto fluido que cambia al variar la luz"

# SURF COLLEC TION

The flowing wave that composes the seat and leg rests of SURF alludes to a sense of calm. It is a soft swell in flux, a fluid gesture that changes to vary light. The method of its creator is the overriding canvas of the world for a new well-being that evokes calmness, casualness, driven by vibrant forms that are refreshing, awakening, and elevating and are metaphors for a new global dynamism.

The pieces are manufactured by rotational moulding, the main characteristic of this technique is that the material is 100% recyclable and it can explore never-ending possibilities in the shapes.

El flujo de la onda que compone SURF alude a una sensación de calma. Es un suave oleaje, un gesto fluido que cambia al variar la luz. El método de su creador es reemplazar el lienzo del mundo para un nuevo bienestar que evoca la calma, informalidad; impulsado por las vibrantes formas que despiertan frescura a un nuevo dinamismo global.

Las piezas están fabricadas mediante la técnica del moldeo rotacional; la principal característica de este proceso es que el material es 100% reciclable y se pueden fabricar infinitas posibilidades en cuanto a formas.



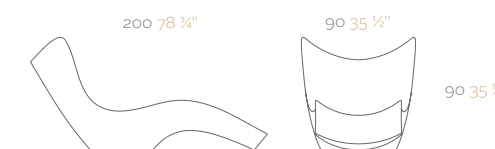

SURF Sun Chaise  
SURF Tumbona



PAL  
COLLEC  
TION  
designed by Karim Rashid

"Dynamic, funny and multifunctional"

"Dinámica, divertida y multifuncional"

# PAL COLLECTION

The minimal iconic shape at the front of the object is revolved around, keeping a constant flow of similarity between the different objects of this collection.

The PAL stool is multi-functional – there is room for storage and when it flips over it becomes a small side table then placed together with a second become an even larger coffee table; there has a hole in lateral plan works as room for storage.

La forma icónica y minimalista que ofrece la vista frontal de la silla envuelve el perímetro de la pieza, guardando un flujo de similitud constante entre los diferentes objetos que forman la colección.

PAL es una colección dinámica y divertida compuesta por silla y taburete, el cual desempeña el papel de objeto multi-funcional puesto que, si se le da la vuelta, se convierte en una mesa de centro, pudiendo aumentar su tamaño uniendo otra pieza; el hueco que tiene en el lateral plano está destinado para ser utilizado como espacio de almacenamiento.

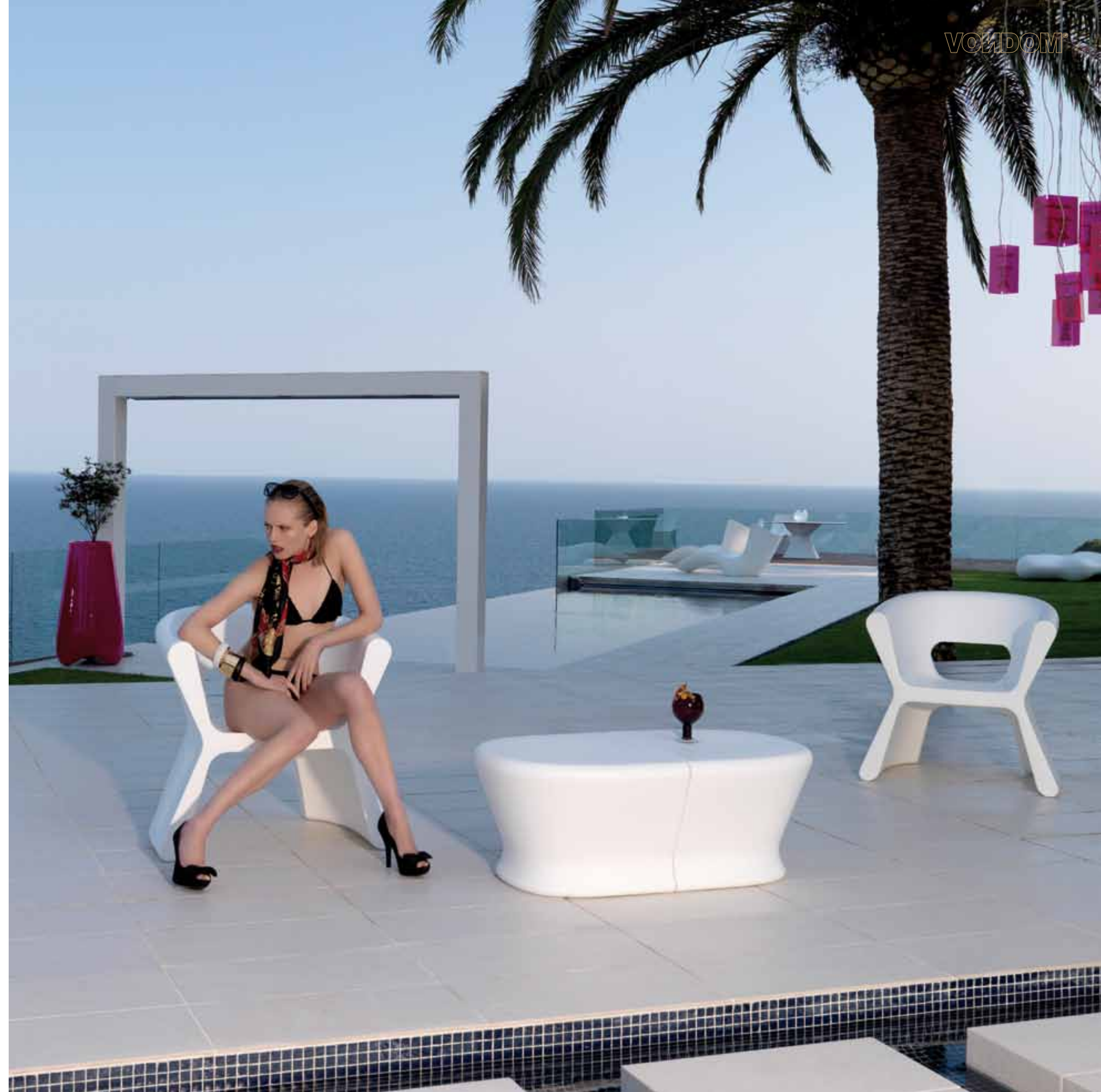
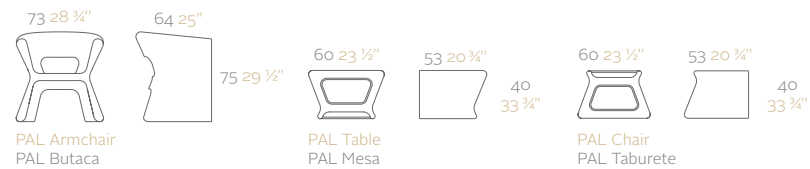



LAVA  
COLLECTION  
designed by Karim Rashid

"Is a unique experience of beauty, luxury, performance and functionality"

"Es una experiencia única que nace de la unión entre belleza, lujo, interpretación y funcionalidad"



# LAVA COLLECTION

LAVA is a unique experience of beauty, luxury, performance and functionality seamless together.

Its avant-garde and original shape creates a pleasant, natural and relaxing gathering spot or connection in any interior & exterior space.

LAVA es una experiencia única que nace de la unión entre belleza, lujo, interpretación y funcionalidad.

Su forma vanguardista y original crea un agradable, natural y relajado lugar de encuentro o conexión en cualquier espacio IN&OUT que se coloque.

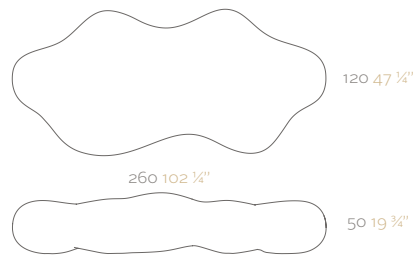

LAVA Bench  
LAVA Banco





# VLEK COLLECTION

designed by Karim Rashid

“Our roots as a human, our roots on this glorious green earth and our growth towards a new future driven by digital technology”

“Raíces como seres humanos, nace de la verde tierra hacia un nuevo futuro conducido por la tecnología digital”



Ø14 Ø5 1/2"  
VLEK Nano Pot 28  
VLEK Nano Maceta 28



Ø18 Ø7"  
VLEK Nano Pot 36  
VLEK Nano Maceta 36



# VLEK COLLECTION

VLEK speaks of our roots as a human, our roots on this glorious green earth and our growth towards a new future driven by digital technology.

Besides its attractive & original design, VLEK also interprets the concept "sustainability of our habitat", since with the option of incorporating a self-watering system, permits an autonomy of watering until 120 days, which guarantees the perfect care for your plants even though you are away on vacation, thanks to its water reservoir and feeding system, the plants learn synchronizing watering and saving water the same moment.

VLEK nos habla de nuestras raíces como seres humanos, nuestro orgulloso origen que nace de la verde tierra hacia un nuevo futuro conducido por la tecnología digital.

A parte de su diseño atractivo y original, VLEK también interpreta el concepto "Sostenibilidad de nuestro hábitat", ya que con la opción de incorporar el sistema de autoriego éste permite una autonomía de riego de hasta 120 días, el cual le garantiza un cuidado absoluto de la planta hasta en períodos de ausencia, gracias a su sistema de alimentación y reserva de agua. La planta aprende a sincronizar el riego y ahorrar agua al mismo tiempo.



VLEK Pot 70  
VLEK Maceta 70



VLEK Pot 100  
VLEK Maceta 100





# CHEMIS TUBES COLLECTION

designed by Teresa Sapey

“How can it be that a vase continues drawing the attention and surprising us?”  
“¿Cómo se puede conseguir que un florero siga llamando la atención y que nos sorprenda?”

# CHEMIS TUBES COLLECTION

CHEMISTUBES, is based on the decontextualization, through the increasing of size (intervention in scale), the use of different materials to the original one (in this case, the ecological material of resin of polyethylene by the technique of rotational moulding), and the change of using for which the object was in the mind at first, gives shape to a new object now. What a laboratory container was before is now a decorative element IN&OUT.

Besides offering the finished in a great variety of matt or lacquered colours, also offers you the value added lighting, in which gives the collection a more interesting touch, creating a surprising, harmonic environment and with great elegance for any interior & exterior space.

CHEMISTUBES, se basa en la descontextualización, a través del aumento de tamaño (intervención en la escala), el uso de materiales diferentes al original (en este caso, material ecológico de resina de polietileno mediante la técnica del moldeo rotacional), y el cambio del uso para el que el objeto fue en un principio pensado, da forma a un nuevo objeto. Lo que antes era un recipiente de laboratorio, es ahora un elemento decorativo IN&OUT.

A parte de ofrecer acabados en una gran variedad de colores mate o lacado, también te ofrece la opción de iluminación incorporada que le aporta a la colección un toque más interesante, creando un ambiente armónico, sorprendente y con gran elegancia para cualquier espacio interior & exterior.



FLASK

A x B  
 Ø36 x 65 Ø14 1/4" x 25 1/2"  
 Ø55 x 100 Ø21 3/4" x 39 1/4"

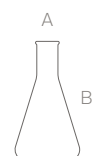

ERLENMEYER

A x B  
 Ø36 x 65 Ø14 1/4" x 25 1/2"  
 Ø55 x 100 Ø21 3/4" x 39 1/4"



PIPE

A x B  
 Ø30 x 65 Ø11 3/4" x 25 1/2"  
 Ø40 x 100 Ø15 3/4" x 39 1/4"





# FIESTA

## COLLECTION

designed by Archirivolto Design

"Beauty and the incessant movility of waves of the sea"  
"Belleza y movilidad incesante de las olas del mar"

# FIESTA COLLECTION

This collection is based in the entertainment places, with the beauty and the incessant mobility of waves. With a simple and functional line, modular but also usable as a single piece.

Inspirada en los lugares de entretenimiento, junto con la belleza y la movilidad incesante de las olas. Con una línea simple y funcional, modular pero también de uso unitario.



VONDOM®



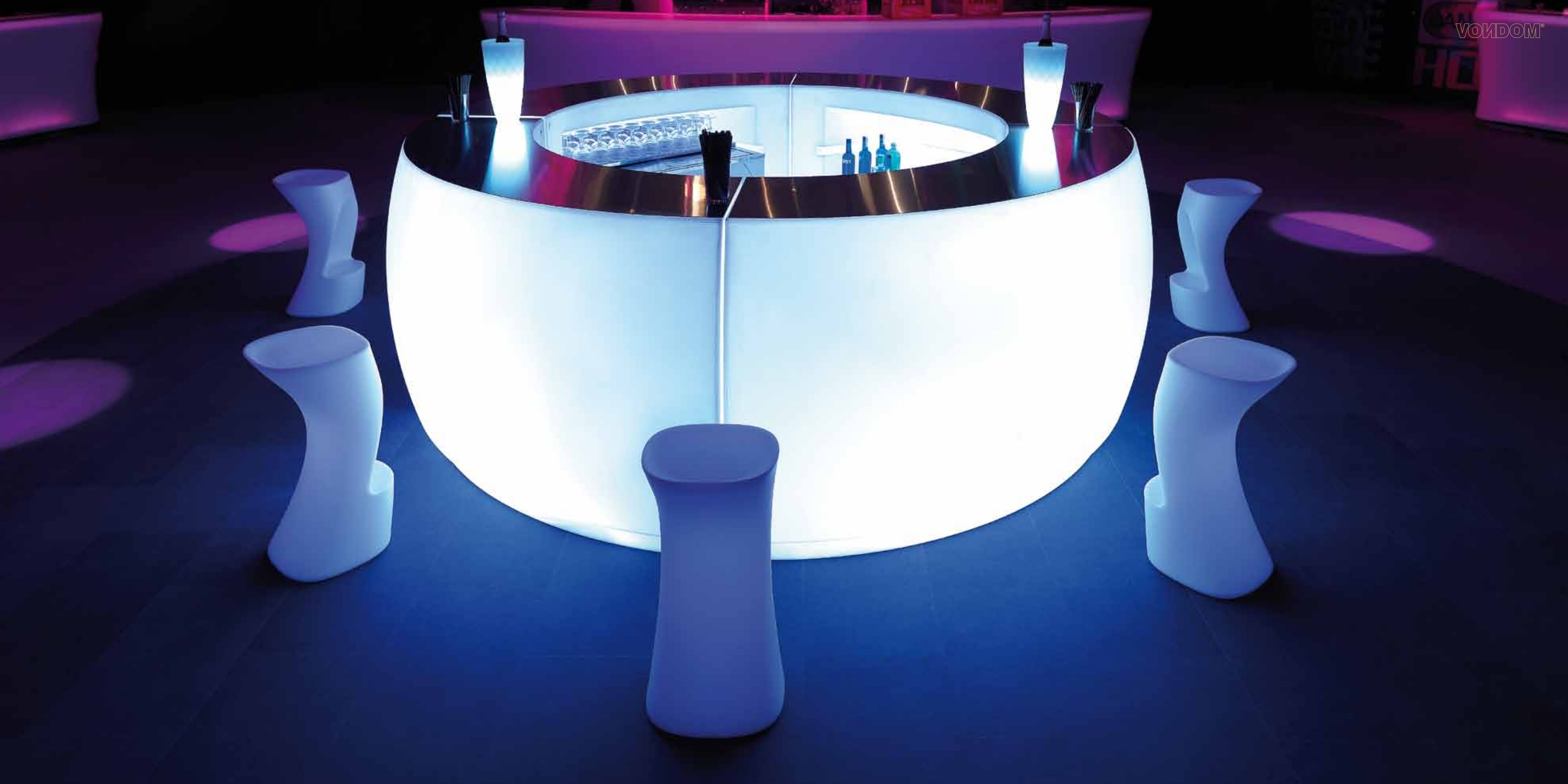

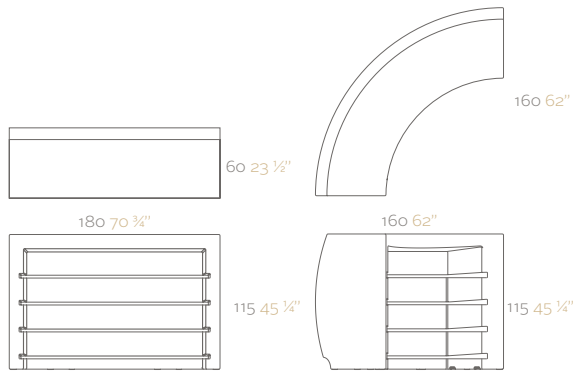

FIESTA Bar  
FIESTA Barra

FIESTA Curve Bar  
FIESTA Barra Curva



PROJECTS  
&EVENTS

PROYECTOS  
YEVENTOS



## VONDOM A LAS TORRES

Valencia Design Week 2011  
Valencia, Spain

Art Director Ramon Esteve



ROYAL OXYGEN SPA  
Tehran, Iran



## FASHION WEEK VALENCIA

September 2011  
Valencia, Spain



NHOW BERLIN HOTEL  
Berlin, Germany

KOM HOUSE  
Cairo, Egypt

Design Karim Rashid





BIG BROTHER  
Madrid, Spain

INSTRUCTIONS  
& RECOMMEN  
DATIONS INSTRU  
CIONES Y RECO  
MENDACIONES

FEATURES,  
COLOUR & FINISHED  
CARAC  
TERÍSTICAS, COLOR  
ES Y ACABADOS

## MAINTENENCE & SECURITY

Our production is made according to the quality guide ISO 9001:2008 and of environment ISO 14001:2004, by only using materials of high quality to guarantee a long useful life of the products.

In order to provide a durable usage and safety to the product, please follow up the following recommendations:

- All our products are suitable for indoor and outdoor spaces.
- The continuous exposure to the sun, especially in the dark colours, the skin can be harmful to the material by direct contact. To avoid these problems, please verify the temperature of the furniture before its long time exposure to the strong sun.
- Place the piece in a regular surface without inclination to avoid uncontrollable movement.
- Keep the piece far away from the excessive heat sources.
- The product is not a toy. To avoid accidents, do not to allow the children to play with them.
- Keep the furniture away from sources of dust to keep them clean. In the case of required cleaning. It is recommended the use of pressured water systems as KARCHER machines and/or domestic degreasing cleanser periodically. Never use abrasive or corrosive products.
- For a better conservation of the products, it is recommended, to cover with the cover fitting to every item.
- The LACQUERED collections are suitable for outdoor, but please pay more attention as they are more delicate, and do not to use pressured water and neither abrasive nor corrosive products. For it, it is recommended to apply automobiles' wax every 2 or 3 months, also will avoid the apparition of possible scratches.
- Outdoor cushions are available for some models. It is recommended to clean them periodically by using a cloth with neuter soap and water.
- Clean the stainless steel part with right products.
- When changing the bulb, please be assured the cable is not connected to the main power.
- If the cable suffers any damage, it must be changed exclusively by the manufacturer or by a professional.
- If the RGB LED is out of order, please do not manipulate it and contact with the manufacturer or distributor.

## CLEANING

It is recommended the use of Scotch-Brite BORRABRITE.

Use a double faceb sponge with water only, with no need of chemical products. The white face removes the dirt and the stains efficiently from multiple surfaces: walls, floors, doors, garden furniture...The blue face makes the work easy with a good result.

It is recommended the use of noncolored degreaser.

Please pulverize with KH-7 on the dirty surface and rub it with a cloth humidified with water. Then please rinse with abundant water (preferably with water pressure systems and dry them outside.

- We hope you enjoy our products. If you need any further information, please do not hesitate to communicate with our CUSTOMER SERVICE department calling to +34 96 239 84 86 o sending e-mail to info@vondom.com.

## MANTENIMIENTO Y SEGURIDAD

Nuestra producción se rige según las normas de nuestro sistema de aseguramiento de la calidad ISO 9001:2008 y de medio ambiente ISO 14001:2004. Y solamente utilizamos materiales de altísima calidad para garantizar una larga vida útil a los productos.

Para proporcionarle un uso duradero y seguro al producto, por favor siga las siguientes instrucciones:

- Todos nuestros productos son aptos tanto para interior como para exterior.
- La exposición continua al Sol, especialmente los colores oscuros, puede provocar lesiones por contacto con la piel. Tenga la precaución de verificar la temperatura de los muebles antes de su uso en horas de sol extremo.
- Coloque la pieza en una superficie regular y sin pendiente para evitar desplazamientos incontrolados.
- Manténgala alejada de fuentes de calor excesivas.
- El producto no es un juguete. No permita que los niños jueguen con ellos, para evitar accidentes.
- Mantenga sus muebles fuera de fuentes de polvo para mantenerlos limpios. En caso de que se requiera su limpieza se recomienda el uso de sistemas de presión de agua tipo KARCHER y/o desengrasantes domésticos de forma periódica. Nunca utilice productos abrasivos o corrosivos.
- Para una mejor conservación del mobiliario, se aconseja cubrir con fundas para cada uno de los artículos.
- Las colecciones LACADAS son aptas para el exterior pero hay que extremar su cuidado puesto que son más delicadas, no debe utilizar agua a presión ni productos abrasivos o corrosivos. Para ello, es aconsejable aplicar cada 2 ó 3 meses cera de carrocería y así eliminar la aparición de posibles arañazos.
- Existen acolchados aptos para el exterior, disponibles para algunas colecciones. Se recomienda limpiarlos periódicamente utilizando un paño con jabón neutro y agua.
- Limpie las partes de acero inoxidable con productos adecuados.
- En caso de sustituir la bombilla, asegúrese de que el cable no está conectado a la corriente eléctrica.
- Si el cable sufre algún deterioro, debe cambiarse exclusivamente por el fabricante o por un profesional.
- Si el LED dejara de funcionar, no manipular en ningún caso y contactar con el fabricante o distribuidor del producto.

## LIMPIEZA

Se recomienda la utilización de Scotch-Brite BORRABRITE.

Espanja de doble cara para un uso sólo con agua, sin necesidad de productos químicos. La cara blanca elimina la suciedad y las manchas eficazmente y de múltiples superficies: paredes, suelos, puertas, muebles de jardín... La cara azul facilita el trabajo y proporciona un buen acabado.

Se recomienda la utilización de KH-7 Quitagrasas

Pulverice con KH-7 sobre la superficie a limpiar y frote con un paño humedecido con agua. Aclare con agua abundante (preferiblemente con un sistema de presión de agua tipo KARCHER) y deje secar al aire libre.

- Esperemos que disfrute de nuestros productos. Si desea más información no dude en comunicárselo a nuestro departamento de ATENCIÓN AL CLIENTE llamando al +34 96 239 84 86 o enviando un correo electrónico a info@vondom.com

## PRODUCT DESCRIPTION

- 1.- Water tank level indicator, verifiable at any time.
- 2.- Expanded clay works as drainage. This will prevent stagnation, control water flow & assure root aeration.
- 3.- Vegetal soil.
- 4.- Self-watering base where the plant absorbs the water.
- 5.- Water tank.
- 6.- Option of wheels o feet.

## PLANTING INSTRUCTIONS

- Set a fine layer of about 2 or 3 cm. in deep of expanded clay on the base of the self-watering base.
- Add the vegetal soil for plants in the flowerpot, leaving space for the root ball of the plant.
- Planting the plant in the flowerpot, previously aerating the roots in order to favour its growth. Finish filling the flowerpot with vegetal soil & press down on the soil with your hands to make it perfectly compact.
- Water the plant on the soil. In the following weeks, please water the plant over the top as the roots of the plant have not reached the platform layer of the self-watering apparatus yet, where the water tank is stored.

## DESCRIPCIÓN DEL PRODUCTO

- 1.- Indicador de nivel de agua del depósito, comprobable en todo momento.
- 2.- Arcilla expandida, actúa como drenaje. Evita el estancamiento, dosifica el transporte del agua y garantiza la aireación de las raíces.
- 3.- Tierra vegetal.
- 4.- Base de autorriego donde la planta absorbe el agua.
- 5.- Depósito de agua.
- 6.- Opción de ruedas o patas.

## INSTRUCCIONES DE PLANTADO

- Ponga una capa fina de arcilla expandida de unos 2 ó 3 cm. de grosor sobre la base del autorriego.
- Añada la tierra vegetal para plantas a la maceta, procurado dejar un hueco para el cepellón de la planta que quiera plantar.
- Plante la planta en la maceta aireando previamente las raíces para favorecer su crecimiento. Acabe de rellenar con tierra vegetal la maceta y presione bien la tierra con las manos para una perfecta compactación
- Riegue la planta sobre la tierra. En las próximas semanas tendrá que regar por encima, ya que las raíces de la planta no han llegado hasta la capa de la plataforma del autorriego, donde se encuentra el depósito del agua.

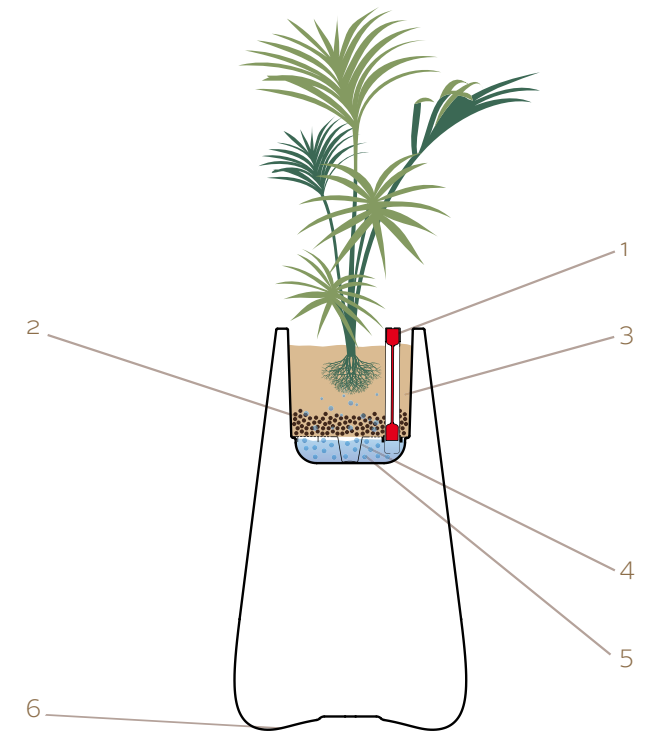

RECOMMENDATIONS

After this period of adaption for the roots, fill the water tank until the top very slowly until the indicator reaches the maximum level. If there is no water, the indicator will be at the minimum level, check the indicator level regularly. The period of watering depends on the flowerpot size, plant type and its location. Consult it with a professional in the sector.

INDOOR (collection LLUM & LED) 

For indoor use, need to check if the stopper of drainage is placed before planting the plant.

OUTDOOR 

For outdoor use, please take off the stopper of drainage (LLUM and LED collection) and drill the holes at the indicated mark, bearing in mind the position of the water tank (AIRE, AIGUA and FOC collections) and also in the base of the flower pot, so that if it rains, the water overflow will evacuate and not harm the plant.

If you cover the soil with a fine layer of KUBIKO, it will stop the moisture from evaporating and improve its aesthetic appearance. For fertilizing and better care of your plants, consult your gardener or your garden centre. VONDOM, accepts no responsibility for any damage done to the plants caused by the incorrect use of flowerpots.

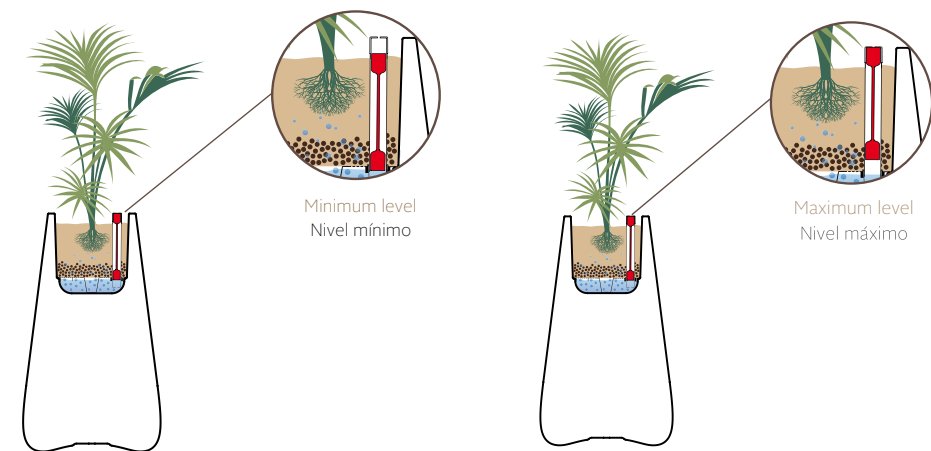

Minimum level  
Nivel mínimo

Maximum level  
Nivel máximo

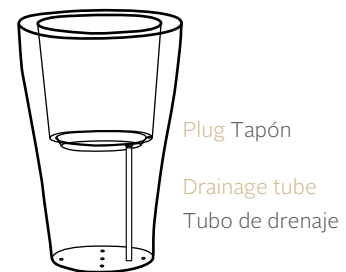

Plug Tapón

Drainage tube  
Tubo de drenaje



Drill Taladrar

PROPORTION KUBIKO 78 Kg/m<sup>2</sup>

Flowerpots application

RELACIÓN KUBIKO 78 Kg/m<sup>2</sup>

Aplicación en macetas

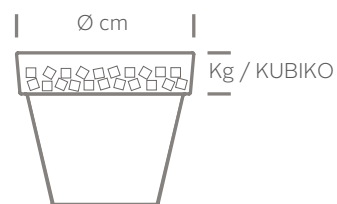

Ø cm	Kg	Ø in	lb
30	5	12"	11
40	10	15 ½"	22
50	15	19 ½"	33
60	30	23 ½"	66
80	45	30 ½"	99
120	90	47"	200

RECOMENDACIONES

Después de este período de adaptación de las raíces, llene el depósito de la reserva del agua al máximo, muy lentamente hasta que el indicador del agua suba hasta su nivel máximo. Si no hay agua el indicador estará al mínimo. Compruebe periódicamente el nivel del indicador del agua. El período de regado depende según el tamaño de maceta, tipo de planta y de su ubicación. Consúltelo con un profesional del sector.

INTERIOR (colección LLUM y LED) 

Para uso interior se tiene que comprobar que el tapón del drenaje esté colocado antes de plantar la planta.

EXTERIOR 

Para uso en el exterior se tiene que sacar el tapón del drenaje (colección LLUM y LED) y taladrar los puntos de precorte respetando la reserva del agua (colección AIRE, AIGUA y FOC) y en la base de la maceta, ya que si llueve el agua sobrante podrá evacuar y no dañará la planta.

Si cubre la tierra con una capa de KUBIKO, evitará que se evapore la humedad y mejorará su aspecto estético. Para el abonado y un mejor cuidado de sus plantas, consulte en su tienda especializada o a un profesional del sector. VONDOM, no se hace responsable de cualquier daño ocurrido en la planta debido a un mal uso de sus macetas.

INSTRUCTION OF THE ENERGY SAVING LAMP

- Unscrewing the exterior screws of the base of the flowerpot.
- Removing the nuts or screws of the base of the lamp (according to the model).
- Unscrewing the glass cover.
- Unscrewing the light bulb to change.

INSTRUCCIONES PARA LÁMPARA DE BAJO CONSUMO

- Desatornillar los tornillos exteriores de la base de la maceta.
- Quitar las tuercas o tornillos de la base de la lámpara (según modelo).
- Desatornillar la cúpula de cristal.
- Desenroscar la bombilla a sustituir.

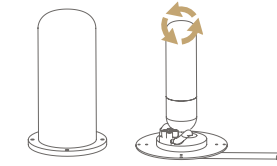
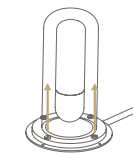
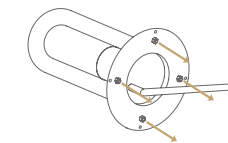
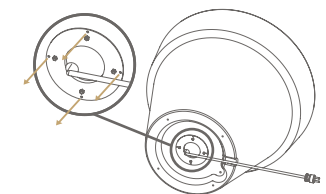

INSTRUCTION OF THE REMOTE CONTROL FOR TECHNOLOGY LED  
INSTRUCCIONES DEL MANDO A DISTANCIA PARA LÁMPARA DE LED

- △ repeat the last order  
repetir la última orden
- manual colour change  
cambio color manual
- automatic color change  
cambio color automático
- ⏻ on/off
- + } intensity regulator  
regulador de intensidad
- }



## FEATURES, COLOUR&FINISHED

CARACTERÍSTICAS, COLORES Y ACABADOS

### MATERIAL FEATURES

- Material: Resin of LLDPE. Low density linear polyethylene.
- Process: Rotational Moulding.
- Resistant to UVl. Factor UV8, equivalent to 8.000 hours of sunlight in Florida.
- Resistant to extreme temperatures (-60°C a + 80°C) / ( -76°F to 176°F)
- Resistant to impact.
- Lightweight
- The pots are easy drilled for making drain holes.
- Recyclable 100%.

### FEATURES: LLUM

- EU: - VOLT. 220-240V ~ 50 - 60Hz      USA: - VOLT. 110-120V ~ 50-60Hz
- WATT: E27 18-30W      - WATT: E26 18-30W
  - Plug type: Shuko Bipolar Antiplash.      - Plug type: USA Plug, 3Pole
  - CE
  - RoHS
- Wire Lenght: 3 m / 118"
- Lamp Type: Energy saving
- IP65

### FEATURES: RGB LED

- System of lighting by LED technology.
- Colour charge by remote control.
- Seven combinations of colors: white / yellow / green / red / light blue / blue / pink.
- Intensity regulator
- 100-240V ~ 50-60Hz
- 350-400 LM
- IP65
- 18 - 72 W
- Long life.

### FEATURES: NANO LLUM (EU)

- VOLT. 220-240V ~ 50 - 60Hz
- Wire Lenght: 2 m / 78" (with switch)
- Lamp Type: LEDs (Ice)
- CE
- Indoor use only.

### CARACTERÍSTICAS DEL MATERIAL

- Material: Resina de LLDPE. Polietileno lineal de baja densidad.
- Proceso: Moldeo rotacional.
- Resistente a UVl. Factor UV8, equivalente a 8.000 horas de sol de Florida.
- Resistente a temperaturas extremas (-60°C a +80°C) / ( -76°F to 176°F)
- Resisistente a impactos.
- Ligera.
- Los maceteros son fáciles de taladrar para realizar las marcas de drenaje.
- Reciclable 100%.

### CARACTERÍSTICAS: LLUM

- EU: - VOLT. 220-240V ~ 50 - 60Hz      USA: - VOLT. 110-120V ~ 50-60Hz
- WATT: E27 18-30W      - WATT: E26 18-30W
  - Tipo de Plug: Shuko Bipolar Antiplash.      - Tipo de Plug: USA Plug, 3Pole
  - CE
  - RoHS
- Longitud Cable: 3 m / 118"
- Tipo de Lámpara: Bajo consumo
- IP65

### CARACTERÍSTICAS: RGB LED

- Sistema de iluminación mediante Tecnología LED.
- Cambio de color mediante mando a distancia.
- Siete combinaciones de colores: blanco / amarillo / verde / rojo / azul claro / azul / pink.
- Regulación de intensidad.
- 100-240V ~ 50-60Hz
- 350-400 LM
- IP65
- 18 - 72 W
- Larga vida.

### CARACTERÍSTICAS: NANO LLUM (EU)

- VOLT. 220-240V ~ 50-60Hz
- Longitud Cable: 2 m / 78" (con interruptor)
- Tipo de Lámpara: LEDs (hielo)
- CE
- Apto para interior

### FEATURES: TAPESTRY

#### NAPA

Composition	97,5 % PVC 2,5 Pollycollon	
Weight	700 gr/m²	
Abrasion	> 40.000 cycles	
Breaking Resistance	Weft > 140 N Warp > 350 N	UNE 4818-92 p. 6
Breaking Elongation	Weft > 250 % Warp > 100 %	UNE 4818-92 p. 6
Tear Resistance	Weft > 80 Warp > 50	UNE 4818-92 p. 6
Fire Retardancy	UNE 9175; 9176 (CLASE 1/IM) M2 FRANCE UNE 1021 (Partes 1-2) BS 5852 (Parte 1)	
Antibacterial Treatment	Yes	
Outdoor using	Yes	

#### FOAM

Density	30/40 Kg
Plasticized	Yes

### FEATURES: HPL BOARD

Features	Method	Units	Value
Thickness	ISO 4586 1/2	13	mm
Density	ISO 1183	Kg/m²	165,44
Water Absorption	ISO 4586 1/2	%	Weight 2,0 max. Thickness 2,0 max.
Dimensional Stability to High Temperatures	ISO 4586 1/2	%	Long. 0,25 max. Trans. 0,55 max.
Hardness	ASTM D 785	HR E	97 ca
Flexion Resistance	ISO 178	MPa MPa	min. 15000 min. 12000

### CARACTERÍSTICAS: TEJIDO

#### NAPA

Composición	97,5 % PVC 2,5 Pollycollon	
Peso	700 gr/m2	
Resistencia a la Abrasión	> 40.000 ciclos	
Resistencia a la Tracción	Trama > 140 N Urdimbre > 350 N	UNE 4818-92 p. 6
Resistencia a la Rotura	Trama > 250 % Urdimbre > 100 %	UNE 4818-92 p. 6
Resistencia al Desgaste	Trama > 80 Urdimbre > 50	UNE 4818-92 p. 6
Tratamiento Ignífugo	UNE 9175; 9176 (CLASE 1/IM) M2 FRANCE UNE 1021 (Partes 1-2) BS 5852 (Parte 1)	
Tratamiento Antibacteriano	Sí	
Apto para exterior	Sí	

#### ESPUMA

Densidad	30/40 Kg
Plastificada	Sí

### CARACTERÍSTICAS: TABLERO HPL

Características	Método	Unidades	Valores
Grosor	ISO 4586 1/2	13	mm
Densidad	ISO 1183	Kg/m²	165,44
Absorción de agua	ISO 4586 1/2	%	Peso 2,0 max. Espesor 2,0 max.
Estabilidad dimensional a altas temperaturas	ISO 4586 1/2	%	Long. 0,25 max. Trans. 0,55 max.
Dureza	ASTM D 785	HR E	97 ca
Resistencia a la flexión	ISO 178	MPa MPa	min. 15000 min. 12000



AIRE

Flowerpot made by resin of polyethylene, with double wall. Product adapts for both indoor and outdoor.

Macetero en resina de polietileno, con doble pared. Producto tanto para interior como exterior.



AIGUA

Flowerpot made by resin of polyethylene, with double wall. Includes self watering system that contributes an automatically water plants to three months. Product adapts for both indoor and outdoor use.

Macetero en resina de polietileno, con doble pared. Contiene sistema de autorriego que aporta una autonomía del riego a la planta de hasta tres meses. Producto tanto para exterior como para interior.



BASIC

Furniture of double wall in polyethylene resin with matte finished. Item suitable for indoor and outdoor use.

Mobiliario fabricado en resina de polietileno acabado mate, con doble pared. Producto tanto para interior como exterior.



FOC

- Flowerpot made by resin of polyethylene, with double wall. Shinning lacquered finishing similar to the car paint. Includes self watering system that contributes an autonomy of watering to the plants until three months. Item suitable for indoor and outdoor use.

- Furniture of double wall in polyethylene resin with shinning lacquered finished with painting for car. Item suitable for indoor and outdoor use.

- Macetero en resina de polietileno, con doble pared. Acabado lacado brillo con pintura para carrocerías. Contiene sistema de autorriego que aporta una autonomía de del riego a la planta de hasta tres meses. Producto tanto para exterior como para interior.

- Mobiliario con doble pared fabricado en resina de polietileno con acabado lacado brillo con pintura para carrocerías. Producto apto tanto para interior como exterior.



LLUM

- Flowerpot made by resin of polyethylene, with double wall. Lighting inside by energy saving lamps. Includes self watering system that contributes an automatically water plants to three months. Item suitable for indoor and outdoor use.

- Furniture of double wall made by resin of polyethylene and ice color finished. Include the white light or different colors such as blue, red or green available with energy saving lamps. Item suitable for indoor and outdoor use.

- Macetero en resina de polietileno, con doble pared. Iluminación en el interior mediante lámpara de bajo consumo. Contiene sistema de autorriego que aporta una autonomía de del riego a la planta de hasta tres meses. Producto tanto para exterior como para interior.

- Mobiliario con doble pared fabricado en resina de polietileno y acabado color hielo. Incluye iluminación interior de color blanco, azul, rojo o verde mediante lámpara de bajo consumo. Producto apto tanto para exterior como para interior.



NANO

Mini flowerpot made by resin of polyethylene, with double wall. Item suitable for indoor and outdoor use..

Macetero en miniatura fabricado en resina de polietileno, con doble pared. Producto apto tanto para exterior como para interior.



NANO LACADAS

Mini flowerpot made by resin of polyethylene, with double wall. Shinning lacquered finishing similar to the car paint. Item suitable for indoor and outdoor use.

Macetero en miniatura fabricado en resina de polietileno, con doble pared. Acabado lacado en brillo con pintura para carrocerías. Producto apto tanto para exterior como para interior.



NANO LLUM

Mini flowerpot made by resin of polyethylene, with double wall. White lighting inside by means of led. Item suitable only for indoor use.

Macetero en miniatura fabricado en resina de polietileno, con doble pared. Iluminación blanca en el interior mediante led. Producto apto SOLO para inerior.



# FEATURES, COLOUR&FINISHED

CARACTERÍSTICAS, COLORES Y ACABADOS



## LED

Flowerpot made by resin of polyethylene, with double wall. Lighting inside by means of led technology and a remote control to program the colours option\*. Includes selfwatering system that contributes an autonomy of watering to the plants until three months. Item suitable for indoor and outdoor.

- Furniture of double wall made by resin of polyethylene and ice color finishing. Includes lighting with led technology, and a remote control to program the colours option. Item suitable for indoor and outdoor.

\*7 colors: white, red, green, blue, light blue, pink and yellow.

Macetero en resina de polietileno, con doble pared. Iluminación en el interior mediante tecnología led. Acompañado de mando a distancia para cambio de color\* por selección o automático. Contiene sistema de autorriego que aporta una autonomía de del riego a la planta de hasta tres meses. Producto tanto para interior como exterior.

Mobilario de doble pared fabricado en resina de polietileno y acabado color hielo. Incluye iluminación interior mediante tecnología led. Acompañado de mando a distancia para cambio de color\* por selección o automático. Producto tanto para interior como exterior.

\*7 colores: blanco, rojo, verde, azul, azul claro, pink y amarillo.

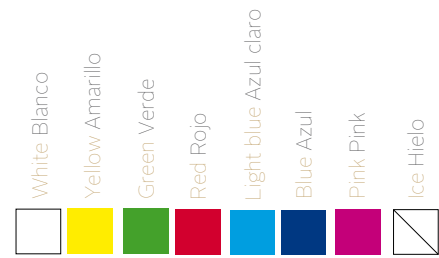

LED COLOURS COLORES LED

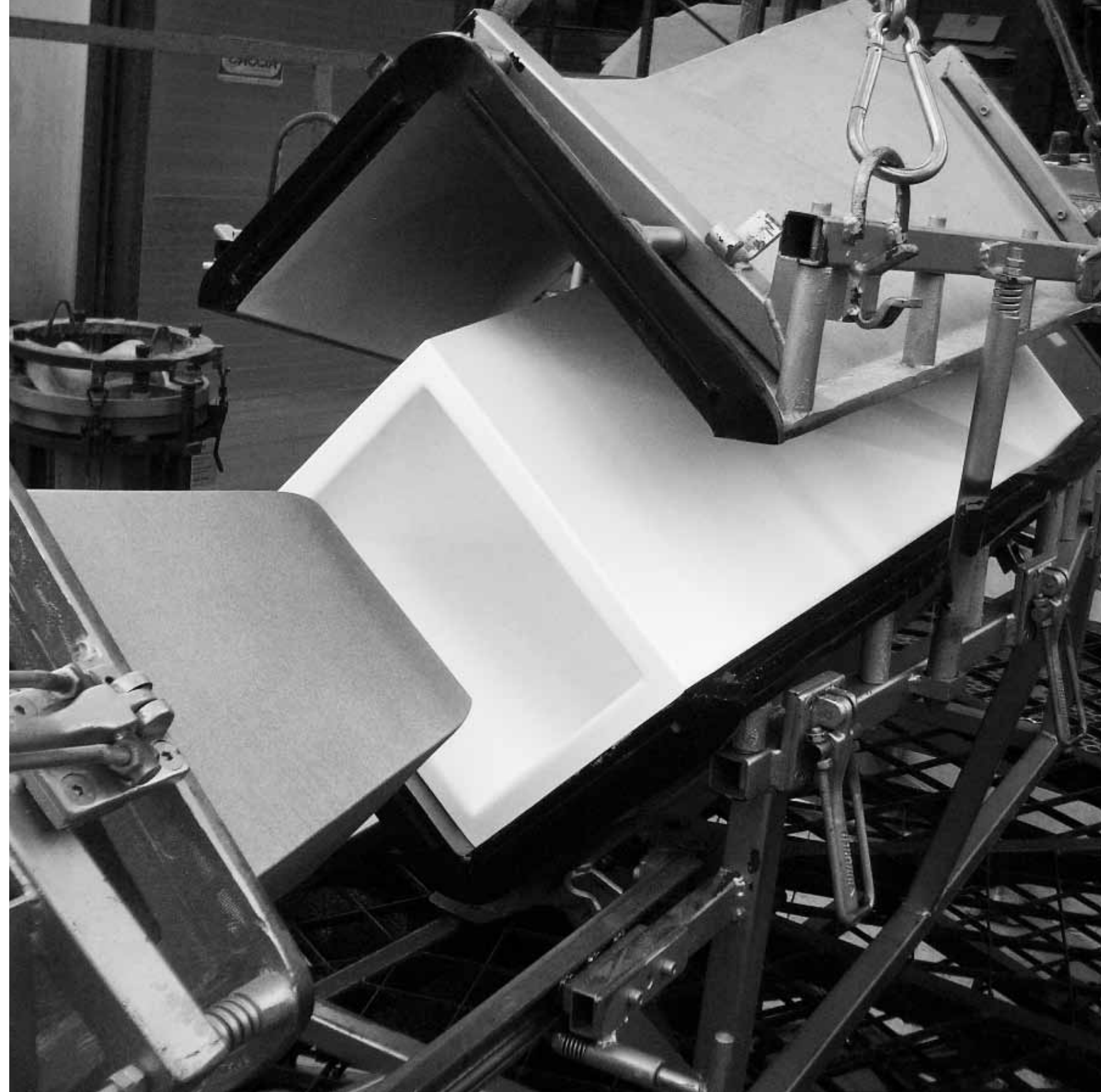

## FEATURES, COLOUR&FINISHED

CARACTERÍSTICAS, COLORES Y ACABADOS

VONDOM®

### FINISHED: CUSHION

- ZANDER

Cushion made by nautical fabric suitable for indoor and outdoor. Standard finished.

- SILVERTEX

Cushion made by vinyl fabric suitable for indoor and outdoor. Special finished.

#### SILVERTEX COLORS



White  
Blanco



Black  
Negro



Bronze  
Bronce



Steel  
Acero



Anthracite  
Antracita



Cream  
Beige

#### COLORES SILVERTEX

### FINISHED: BOARD

- HPL

Are boards made from paper capes agglutinated with thermoset resins of Melamina-Formaldehido on the surface and Fenol-Formaldehido inside. Everything is pressed to high temperature and pressure. Product suitable for indoor and outdoor .

- GLASS

12 mm. security temperate glass.

### FINISHED: LIGHTING

- LLUM

Lighting of double wall made by polyethylene resin and ice colour finished. Include the white light or different colours such as blue, red or green, available with energy saving lamps. Item suitable for indoor and outdoor.

- LED RGB

Lighting of double wall made by polyethylene resin and ice colour finished. Includes lighting with the led technology and a remote control to program the colours option (7 colours: white, red, green, blue, light blue, pink and yellow). Item suitable for indoor and outdoor.

### ACABADOS: COLCHONETA

- ZANDER

Acolchado en tejido náutico apto para interior y exterior. Acabado estandard.

- SILVERTEX

Acolchado en tejido vinílico apto para interior y exterior. Acabado especial.

#### COLORES SILVERTEX

### ACABADOS: TABLEROS

- HPL

Son tableros que se componen de capas de papel aglutinado con resinas termoestables de Melamina-Formaldehido en su superficie y de Fenol-Formaldehido en su interior. Todo ello es prensado a alta presión y alta temperatura. Producto apto para interior y exterior.

- GLASS

Cristal templado de seguridad 12 mm.

### ACABADOS: ILUMINACIÓN

- LLUM

Lámpara de doble pared fabricado en resina de polietileno y acabado color hielo. Incluye iluminación interior de color blanco, azul, rojo o verde mediante lámpara de bajo consumo. Producto apto para interior y exterior.

- LED RGB

Lámpara de doble pared fabricado en resina de polietileno y acabado color hielo. Incluye iluminación interior mediante tecnología LED. Acompañado de mando a distancia para cambio de color por selección o automático (7 colores: blanco, rojo, verde, azul, azul claro, pink y amarillo). Producto apto para interior y exterior.

### FINISHED: SPECIAL LACQUERED

#### LAPIS

This finishing has a volcanic stone effect, characterized from a particular, fine and opaque texture which gives a pleasant touch to supports. Very good cleaning.



Forge  
Forja  
LP.903.P



Bronze  
Bronce  
LP.810.P



Steel  
Acero  
LP.005.P

### FINISHED: SPECIAL LACQUERED

#### FLAMA

This finishing has a metallic effect characterized from an anodized aspect, which is able to give thickness and resistance even to lighter and softer supports. Very good cleaning.



Gold  
Oro  
FL.112.P

### ACABADOS: LACADOS ESPECIALES

#### LAPIS

Acabado con efecto piedra volcánica. Óptima limpieza.

### ACABADOS: LACADOS ESPECIALES

#### FLAMA

Acabado con efecto metalizado caracterizado por un aspecto anodizado, aporta dureza y resistencia incluso en las superficies más blandas. Óptima limpieza.



DIMEN  
SIONSDIME  
NSIONES

# ALMA COLLECTION

designed by A-cero

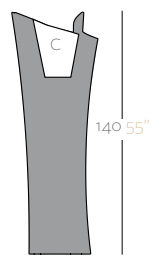
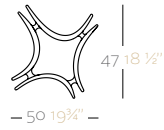

ALMA Pot  
ALMA Macetero

	L Gal	C(d x h) cm in	AIGUA	FOC	LLUM	LED RGB
Alma	10 2 1/4	20 x 24 7 3/4" x 9 1/2"	53013 <sup>b</sup>	53013F <sup>b</sup>	53013W <sup>bi</sup>	53013L <sup>bi</sup>

# REST COLLECTION

designed by A-cero

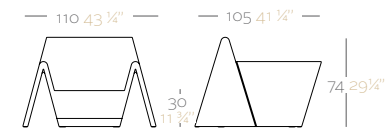

REST Longe Chair  
REST Butaca

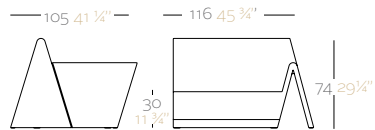

REST Sofa Left Unit  
REST Sofá Módulo Izquierdo

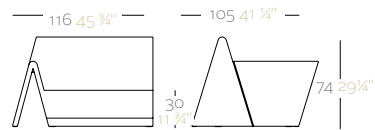

REST Sofa Right Unit  
REST Sofá Módulo Derecho

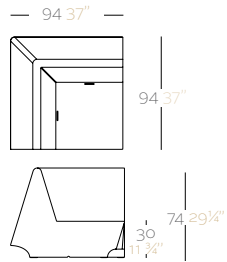

REST Sofa Corner Unit  
REST Sofá Módulo Esquina

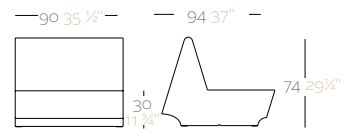

REST Sofa Central Unit  
REST Sofá Módulo Central



REST Chaise-longue  
REST Chaise-longue

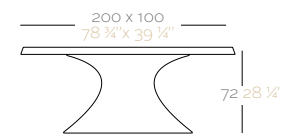

REST Table 200  
REST Mesa 200

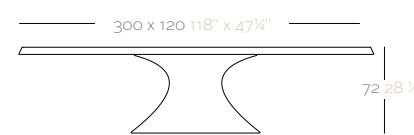

REST Table XL  
REST Mesa XL

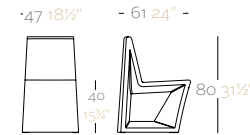

REST Chair  
REST Silla

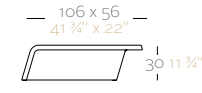

REST Table Sofa  
REST Mesa Sofá

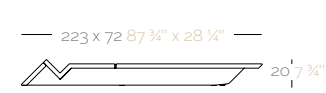

REST Sun Chaise  
REST Tumbona

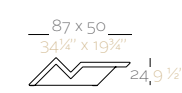

REST Table Sun Chaise  
REST Mesa Tumbona

	Lounge Chair Butaca	Sofa Left Unit M. Izq	Sofa Right Unit M. Dch	Sofa Central Unit M. Central	Sofa Corner Unit M. Esquina	Chaise Chaise	Table Sofa Mesa sofá	Sun Chaise Tumbona	Table Sun Chaise Mesa Tumbona	Table 200 Mesa 200	Table XL Mesa XL	Chair Silla
BASIC	53001* <sup>t</sup>	53002* <sup>te</sup>	53003* <sup>te</sup>	53004* <sup>te</sup>	53005* <sup>te</sup>	53006* <sup>t</sup>	53007 <sup>t</sup>	53008* <sup>am</sup>	53009 <sup>t</sup>	53010 <sup>t</sup>	53011 <sup>t</sup>	53012 <sup>t</sup>
FOC	53001F* <sup>t</sup>	53002F* <sup>te</sup>	53003F* <sup>te</sup>	53004F* <sup>te</sup>	53005F* <sup>te</sup>	53006F* <sup>t</sup>	53007F <sup>t</sup>	53008F* <sup>am</sup>	53009F <sup>t</sup>	53010F <sup>t</sup>	53011F <sup>t</sup>	53012F <sup>t</sup>
LLUM	53001W* <sup>t</sup>	53002W* <sup>te</sup>	53003W* <sup>te</sup>	53004W* <sup>te</sup>	53005W* <sup>te</sup>	53006W* <sup>t</sup>	53007W <sup>t</sup>	53008W* <sup>am</sup>	53009W <sup>t</sup>	-	-	-
LED BLANCO	-	-	-	-	-	-	-	-	-	53010W <sup>t</sup>	53011W <sup>t</sup>	-
LED RGB	53001L* <sup>t</sup>	53002L* <sup>te</sup>	53003L* <sup>te</sup>	53004L* <sup>te</sup>	53005L* <sup>te</sup>	53006L* <sup>t</sup>	53007L <sup>t</sup>	53008L* <sup>am</sup>	53009L <sup>t</sup>	53010L <sup>t</sup>	53011L <sup>t</sup>	-
FULL WHITE	-	-	-	-	-	-	-	-	-	53010B <sup>t</sup>	53011B <sup>t</sup>	-
FOC FULL WHITE	-	-	-	-	-	-	-	-	-	53010FB <sup>t</sup>	53011FB <sup>t</sup>	-
LLUM FULL WHITE	-	-	-	-	-	-	-	-	-	53010WB <sup>t</sup>	53011WB <sup>t</sup>	-
LED FULL WHITE	-	-	-	-	-	-	-	-	-	53010LB <sup>t</sup>	53011LB <sup>t</sup>	-
GLASS	-	-	-	-	-	-	-	-	-	53010G <sup>t</sup>	53011G <sup>t</sup>	-
FOC GLASS	-	-	-	-	-	-	-	-	-	53010BG <sup>t</sup>	53011BG <sup>t</sup>	-
LLUM GLASS	-	-	-	-	-	-	-	-	-	53010WG <sup>t</sup>	53011WG <sup>t</sup>	-
LED GLASS	-	-	-	-	-	-	-	-	-	53010LG <sup>t</sup>	53011LG <sup>t</sup>	-
Cushion Acolchado	-	-	-	-	-	-	-	-	-	-	-	53012C

Thick Cushion: 10 cm / 4" Grosor Acolchado: 10 cm  
Thick Cushion Chair: 4 cm / 1 1/2" Grosor Acolchado Silla: 4 cm

b\_ self-watering included.  
l\_ possibility of transparent cable & switch for indoor.  
b\_ incluye sistema de autoriego.  
l\_ posibilidad de cable transparente e interruptor para interior.

\*\_ cushions are included in the prize  
a\_ wheels included  
t\_ non-slipping feet included  
m\_ moving headrest  
e\_ join set in order to fix them together

\*\_ acolchados incluidos en el precio  
a\_ incluye ruedas  
t\_ incluye tacos antideslizantes  
m\_ cabeza móvil  
e\_ incluye un set de ensamblaje para fijarlos entre ellos

DIMENSIONS DIMENSIONES

BLANCA COLLECTION designed by Javier Mariscal

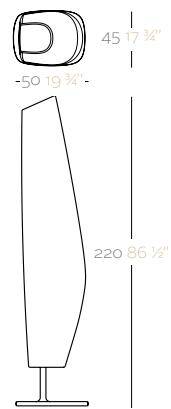

BLANCA Lamp  
BLANCA Lámpara

	LED <b>LED</b>	LED RGB <b>LED</b>
BLANCA	46050W <sup>i</sup>	46050L <sup>i</sup>

MORA COLLECTION designed by Javier Mariscal

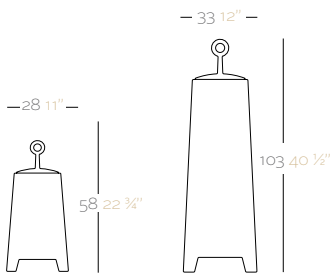

MORA Lamp 28  
MORA Lámpara 28

MORA Lamp 33  
MORA Lámpara 33

	LLUM <b>☾</b>	LED RGB <b>LED</b>
MORA 28	46028W <sup>i</sup>	46028L <sup>i</sup>
MORA 33	46033W <sup>i</sup>	46033L <sup>i</sup>

<sup>i</sup> possibility of transparent cable & switch for indoor  
<sup>i</sup> posibilidad de cable transparente e interruptor para interior

MOMA COLLECTION designed by Javier Mariscal

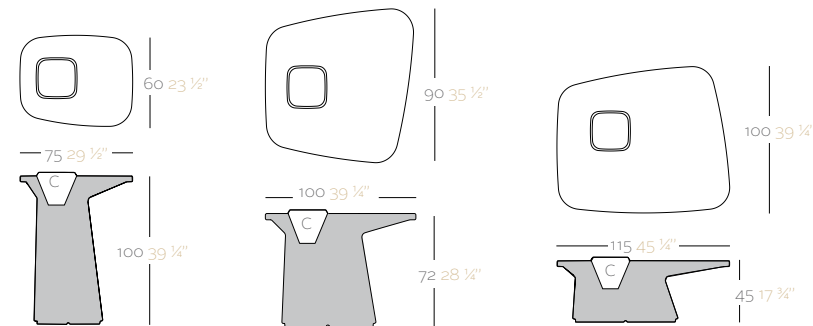

MOMA Table High  
MOMA Mesa High

MOMA Table Medium  
MOMA Mesa Medium

MOMA Table Low  
MOMA Mesa Low

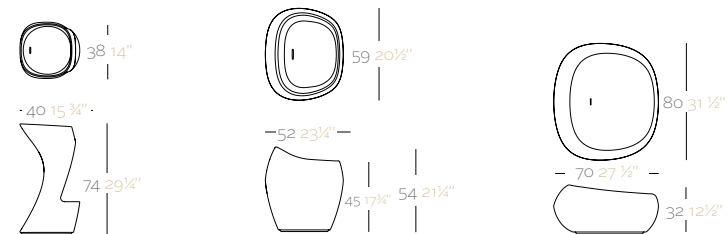

MOMA Bar Stool  
MOMA Taburete

MOMA Chair  
MOMA Silla

MOMA Puff  
MOMA Puff

	L Gal	C (d x h) cm in	BASIC <b>B</b>	AIGUA <b>💧</b>	FOC <b>🔦</b>	LLUM <b>☾</b>	LED RGB <b>LED</b>
High	7 1 3/4"	20 x 20 7 3/4" x 7 3/4"	45075A	45075R <sup>b</sup>	45075F <sup>b</sup>	45075W <sup>b</sup>	45075L <sup>b</sup>
Medium	7 1 3/4"	20 x 20 7 3/4" x 7 3/4"	45100A	45100R <sup>b</sup>	45100F <sup>b</sup>	45100W <sup>b</sup>	45100L <sup>b</sup>
Low	7 1 3/4"	20 x 20 7 3/4" x 7 3/4"	45115A	45115R <sup>b</sup>	45115F <sup>b</sup>	45115W <sup>b</sup>	45115L <sup>b</sup>
Bar Stool Taburete	-	-	45038A	-	45038F	45038W <sup>i</sup>	45038L <sup>i</sup>
Chair Silla	-	-	45059A	-	45059F	45059W <sup>i</sup>	45059L <sup>i</sup>
Puff	-	-	45080A	-	45080F	45080W <sup>i</sup>	45080L <sup>i</sup>
Ice-Bucket Cubitera	-	-	45001A	-	-	-	-

<sup>b</sup> sell-watering included.  
<sup>i</sup> possibility of transparent cable & switch for indoor.  
<sup>b</sup> incluye sistema de autoriego.  
<sup>i</sup> posibilidad de cable transparente e interruptor para interior.

# MOMA MACETAS COLLECTION

designed by Javier Mariscal

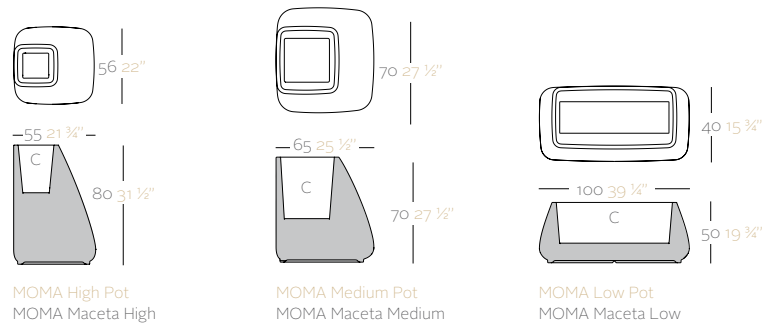

	L Gal	C (d X h) cm in	AIRE	AIGUA	FOC	LLUM	LED RGB <b>LED</b>
High	29 7 3/4	52 x 39 x 26 20 3/4" x 15 1/2" x 10"	45005A	45005R <sup>b</sup>	45005F <sup>b</sup>	45005W <sup>bi</sup>	45005L <sup>bi</sup>
Medium	48 7 3/4	30 x 30 x 32,5 12" x 12" x 13"	45004A	45004R <sup>b</sup>	45004F <sup>b</sup>	45004W <sup>bi</sup>	45004L <sup>bi</sup>
Low	76,5 20 1/4	36,5 x 77,5 x 27 14 1/2" x 30 3/4" x 10 1/2"	45006A	45006R <sup>b</sup>	45006F <sup>b</sup>	45006W <sup>bi</sup>	45006L <sup>bi</sup>

# MOMA MELLIZAS COLLECTION

designed by Javier Mariscal

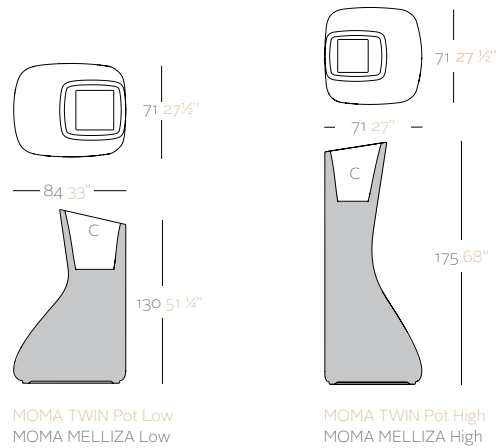

	L Gal	C (d X h) cm in	AIRE	AIGUA	FOC	LLUM	LED RGB <b>LED</b>
High	42 11	37 x 29 x 39 14 1/2" x 11 1/2" x 15 1/2"	45002A	45002R <sup>b</sup>	45002F <sup>b</sup>	45002W <sup>bi</sup>	45002L <sup>bi</sup>
Low	63 16 3/4	44 x 37 x 39 17 3/4" x 14 1/2" x 15 1/2"	45003A	45003R <sup>b</sup>	45003F <sup>b</sup>	45003W <sup>bi</sup>	45003L <sup>bi</sup>

b\_ sell-watering included.  
 i\_ possibility of transparent cable & switch for indoor.  
 b\_ incluye sistema de autoriego.  
 i\_ posibilidad de cable transparente e interruptor para interior.

# VLEK COLLECTION

designed by Karim Rashid

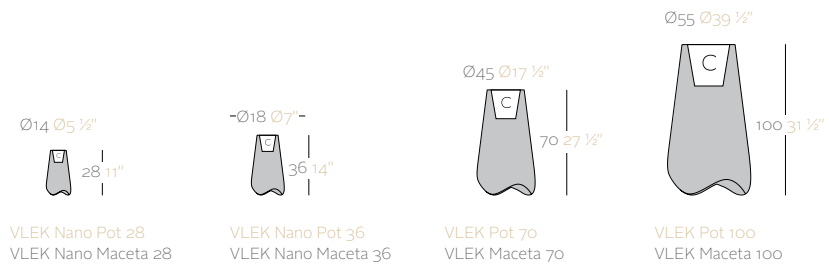

	L Gal	C (d X h) cm in	AIRE	AIGUA	FOC	LLUM	LED RGB <b>LED</b>	NANO LED <b>nano</b>
Nano 28	1 1/4	Ø7 x 14 Ø3" x 5 1/2"	51015A	-	51015F	-	-	51015W
Nano 36	2 1/4	Ø9 x 19 Ø5 1/2" x 7 1/2"	51016A	-	51016F	-	-	51016W
Pot Maceta 70	10 2 1/2	Ø24 x 24 Ø17 1/2" x 17 1/2"	51013A	51013R <sup>b</sup>	51013F <sup>b</sup>	51013W <sup>bi</sup>	51003L <sup>bi</sup>	-
Pot Maceta 100	20 5 1/2	Ø30 x 32 Ø12" x 17 1/2"	51014A	51014R <sup>b</sup>	51014F <sup>b</sup>	51014W <sup>bi</sup>	51004L <sup>bi</sup>	-

# PASTA COLLECTION

designed by Karim Rashid

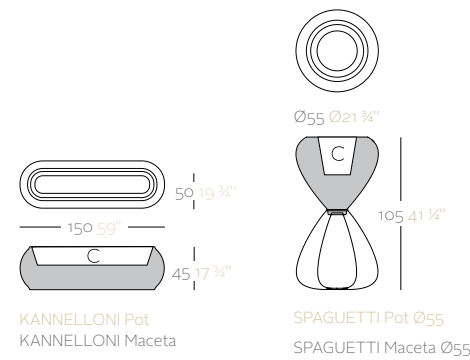

	L Gal	C (d X h) cm in	AIRE	AIGUA	FOC	LLUM	LED RGB <b>LED</b>
Kannelloni	25 6 1/2	Ø9 x 19 Ø3 1/2" x 7 1/2"	51024A	51024R <sup>b</sup>	51024F <sup>b</sup>	51024W <sup>bi</sup>	51024L <sup>bi</sup>
Spaguetti	25 6 1/2	Ø9 x 19 Ø3 1/2" x 7 1/2"	51022A	51022R <sup>b</sup>	51022F <sup>b</sup>	51022W <sup>bi</sup>	51022L <sup>bi</sup>

b\_ sell-watering included.  
 i\_ possibility of transparent cable & switch for indoor.  
 b\_ incluye sistema de autoriego.  
 i\_ posibilidad de cable transparente e interruptor para interior.

# VERTEX COLLECTION

designed by Karim Rashid

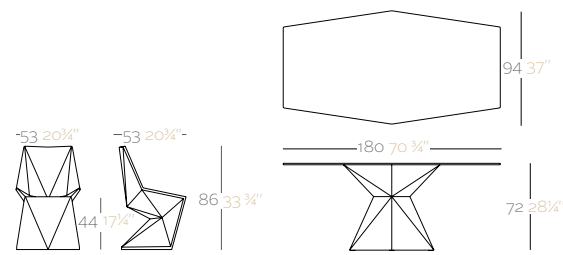

VERTEX Chair  
VERTEX Silla

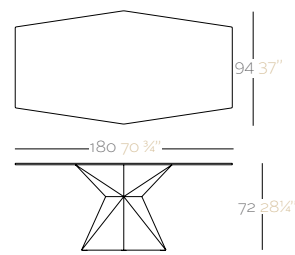

VERTEX Table 180  
VERTEX Mesa 180

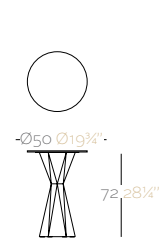

VERTEX Table Ø19 3/4"  
VERTEX Mesa Ø50

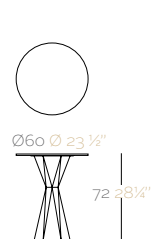

VERTEX Table Ø23 1/2"  
VERTEX Mesa Ø60

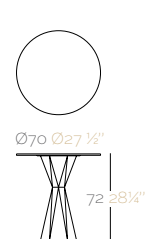

VERTEX Table Ø27 1/2"  
VERTEX Mesa Ø70

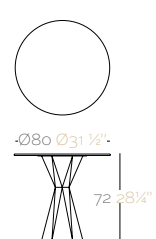

VERTEX Table Ø31 1/2"  
VERTEX Mesa Ø80

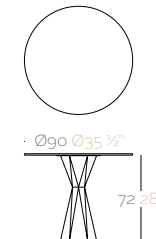

VERTEX Table Ø35 1/2"  
VERTEX Mesa Ø90

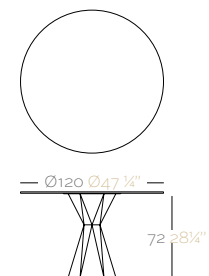

VERTEX Table Ø47 1/4"  
VERTEX Mesa Ø120

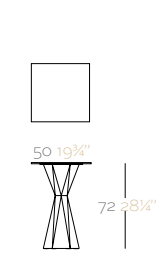

VERTEX Square Table 50  
VERTEX Mesa Cuadrada 50

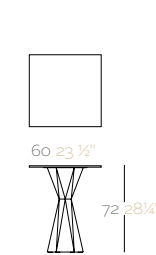

VERTEX Square Table 60  
VERTEX Mesa Cuadrada 60

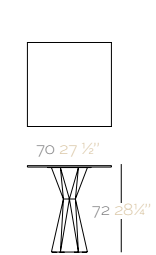

VERTEX Square Table 70  
VERTEX Mesa Cuadrada 70

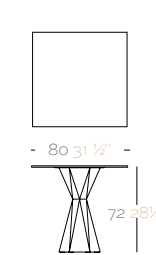

VERTEX Square Table 80  
VERTEX Mesa Cuadrada 80

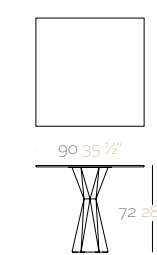

VERTEX Square Table 90  
VERTEX Mesa Cuadrada 90

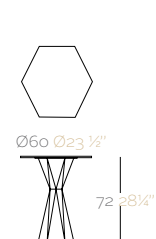

VERTEX Hexagonal Table Ø60  
VERTEX Mesa Hexagonal Ø60

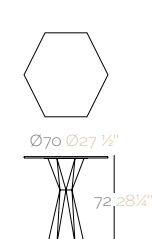

VERTEX Hexagonal Table Ø70  
VERTEX Mesa Hexagonal Ø70

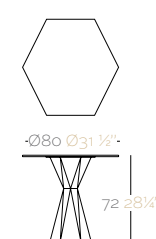

VERTEX Hexagonal Table Ø80  
VERTEX Mesa Hexagonal Ø80

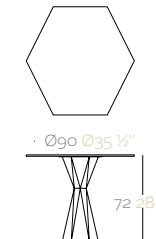

VERTEX Hexagonal Table Ø90  
VERTEX Mesa Hexagonal Ø90

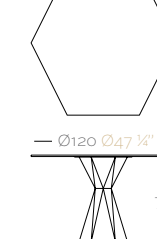

VERTEX Hexagonal Table Ø120  
VERTEX Mesa Hexagonal Ø120

	Chair Silla	Table 180 Mesa 180	Table Ø19 3/4" Mesa Ø50	Table Ø23 1/2" Mesa Ø60	Table Ø27 1/2" Mesa Ø70	Table Ø31 1/2" Mesa Ø80	Table Ø35 1/2" Mesa Ø90	Table Ø47 1/4" Mesa Ø120
BASIC <b>B</b>	51007	51008	51017	51010	51009	51019	51018	51020
FOC <b>F</b>	51007F	51008F	51017F	51010F	51009F	51019F	51018F	51020F
LLUM <b>L</b>	51007W <sup>i</sup>	51008W <sup>i</sup>	51017W <sup>i</sup>	51010W <sup>i</sup>	51009W <sup>i</sup>	51019W <sup>i</sup>	51018W <sup>i</sup>	51020W <sup>i</sup>
LED RGB <b>LED</b>	51007L <sup>i</sup>	51008L <sup>i</sup>	51017L <sup>i</sup>	51010L <sup>i</sup>	51009L <sup>i</sup>	51019L <sup>i</sup>	51018L <sup>i</sup>	51020L <sup>i</sup>
FULL WHITE	-	51008B	51017B	51010B	51009B	51019B	51018B	51020B
FOC FULL WHITE	-	51008FB	51017FB	51010FB	51009FB	51019FB	51018FB	51020FB
LLUM FULL WHITE	-	51008WB <sup>i</sup>	51017WB <sup>i</sup>	51010WB <sup>i</sup>	51009WB	51019WB <sup>i</sup>	51018WB <sup>i</sup>	51020WB <sup>i</sup>
LEDS FULL WHITE	-	51008LB <sup>i</sup>	51017LB <sup>i</sup>	51010LB <sup>i</sup>	51009LB	51019LB <sup>i</sup>	51018LB <sup>i</sup>	51020LB <sup>i</sup>
GLASS		51008G	-	-	-	-	-	-
FOC GLASS		51008FG	-	-	-	-	-	-
LLUM GLASS		51008WB <sup>i</sup>	-	-	-	-	-	-
LED GLASS		51008LG <sup>i</sup>	-	-	-	-	-	-
Cushion Acolchado	51007C	-	-	-	-	-	-	-

	Table Ø50 Mesa Ø50	Table Ø60 Mesa Ø60	Table Ø70 Mesa Ø70	Table Ø80 Mesa Ø80	Table Ø90 Mesa Ø90	Table H 60 Mesa H60	Table H 70 Mesa H70	Table H 80 Mesa H80	Table H 90 Mesa H90	Table H 120 Mesa H120
BASIC <b>B</b>	51017C	51010C	51009C	51019C	51018C	51010E	51009E	51019E	51018E	51020E
FOC <b>F</b>	51017CF	51010CF	51009CF	51019CF	51018CF	51010EF	51009EF	51019EF	51018EF	51020EF
LLUM <b>L</b>	51017CW <sup>i</sup>	51010CW <sup>i</sup>	51009CW <sup>i</sup>	51019CW <sup>i</sup>	51018CW <sup>i</sup>	51010EW <sup>i</sup>	51009EW <sup>i</sup>	51019EW <sup>i</sup>	51018EW <sup>i</sup>	51020EW <sup>i</sup>
LED RGB <b>LED</b>	51017CL <sup>i</sup>	51010CL <sup>i</sup>	51009CL <sup>i</sup>	51019CL <sup>i</sup>	51018CL <sup>i</sup>	51010EL <sup>i</sup>	51009EL <sup>i</sup>	51019EL <sup>i</sup>	51018EL <sup>i</sup>	51020EL <sup>i</sup>
FULL WHITE	51017CB	51010CB	51009CB	51019CB	51018CB	51010EB	51009EB	51019EB	51018EB	51020EB
FOC FULL WHITE	51017CFB	51010CFB	51009CFB	51019CFB	51018CFB	51010EFB	51009EFB	51019EFB	51018EFB	51020EFB
LLUM FULL WHITE	51017CWB <sup>i</sup>	51010CWB <sup>i</sup>	51009CWB <sup>i</sup>	51019CWB <sup>i</sup>	51018CWB <sup>i</sup>	51010EWB <sup>i</sup>	51009EWB <sup>i</sup>	51019EWB <sup>i</sup>	51018EWB <sup>i</sup>	51020EWB <sup>i</sup>
LEDS FULL WHITE	51017CLB <sup>i</sup>	51010CLB <sup>i</sup>	51009CLB <sup>i</sup>	51019CLB <sup>i</sup>	51018CLB <sup>i</sup>	51010ELB <sup>i</sup>	51009ELB <sup>i</sup>	51019ELB <sup>i</sup>	51018ELB <sup>i</sup>	51020ELB <sup>i</sup>

<sup>i</sup> possibility of transparent cable & switch for indoor.

<sup>i</sup> posibilidad de cable transparente e interruptor para interior.

# DOUX COLLECTION

designed by Karim Rashid

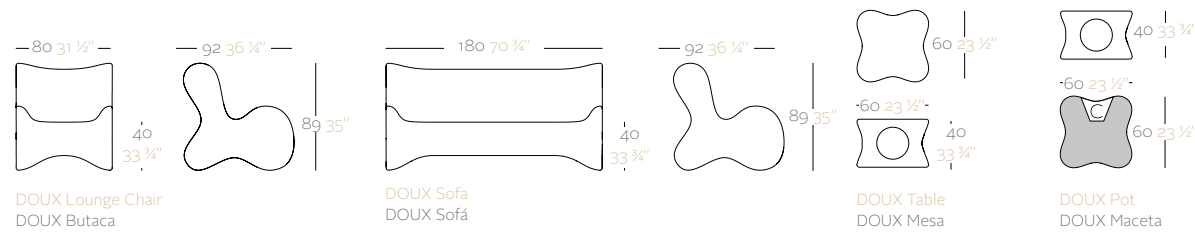

	L Gal	C (d X h) cm in	BASIC <b>B</b>	AIGUA <b>A</b>	FOC <b>F</b>	LLUM <b>L</b>	LED RGB <b>LED</b>
Lounge Chair Butaca	-	-	51001	-	51001F	51001W <sup>i</sup>	51001L <sup>i</sup>
Sofa Sofá	-	-	51002	-	51002F	51002W <sup>i</sup>	51002L <sup>i</sup>
Table Mesa	-	-	51003	-	51003F	51003W <sup>i</sup>	51003L <sup>i</sup>
Pot Maceta	10 2¼	Ø22 x 22 7 ¾" x 7 ¾"	-	51004R <sup>b</sup>	51004F <sup>b</sup>	51004W <sup>ib</sup>	51004L <sup>ib</sup>

# SURF COLLECTION

designed by Karim Rashid

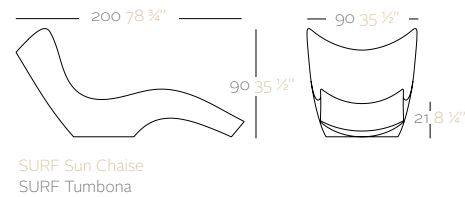

	BASIC <b>A</b>	FOC <b>F</b>	LLUM <b>L</b>	LED RGB <b>LED</b>
Surf	51011	51011F	51011W <sup>i</sup>	51011L <sup>i</sup>

b\_ sell-watering included.  
 i\_ possibility of transparent cable & switch for indoor.  
 b\_ incluye sistema de autoriego.  
 i\_ posibilidad de cable transparente e interruptor para interior.

# PAL COLLECTION

designed by Karim Rashid

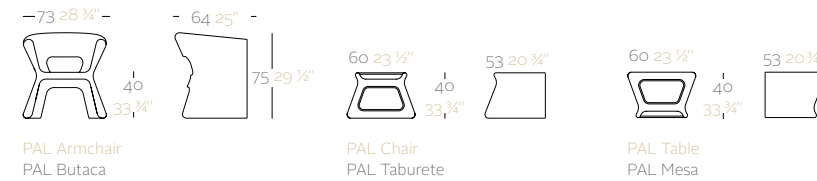

	BASIC <b>B</b>	FOC <b>F</b>	LLUM <b>L</b>	LED RGB <b>LED</b>	Cushion Acolchado*
Armchair Butaca	51005	51005F	51005W	51005L	51005C
Chair Taburete	51006	51006F	51006W	51006L	-
Table Mesa	51006	51006F	51006W	51006L	-

\*Thick Cushion ArmChair: 4 cm / 1 ½ Grosor Acolchado Butaca: 4 cm

# LAVA COLLECTION

designed by Karim Rashid

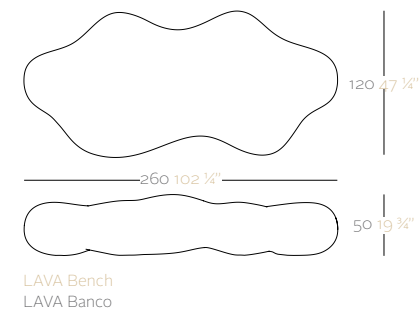

	BASIC <b>A</b>	FOC <b>F</b>	LLUM <b>L</b>	LED RGB <b>LED</b>	Kit Ceilling Holder Colgante
Lava	51012	51012F	51012W <sup>i</sup>	51012L <sup>i</sup>	51012X

i\_ possibility of transparent cable & switch for indoor.  
 i\_ posibilidad de cable transparente e interruptor para interior.

# FAZ COLLECTION

designed by Ramon Esteve

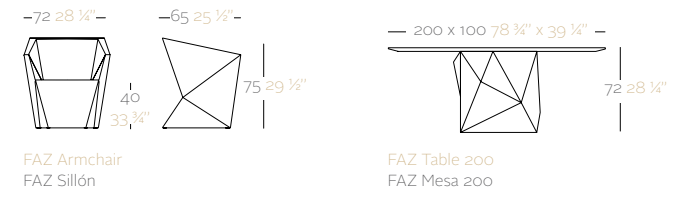
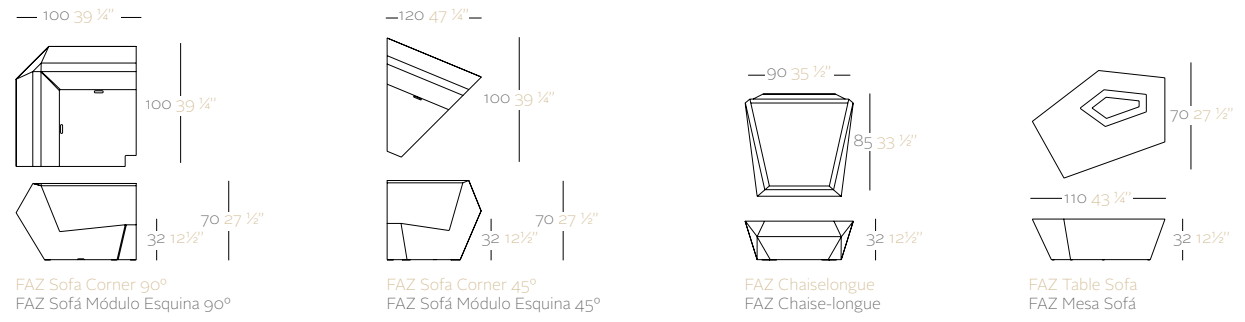
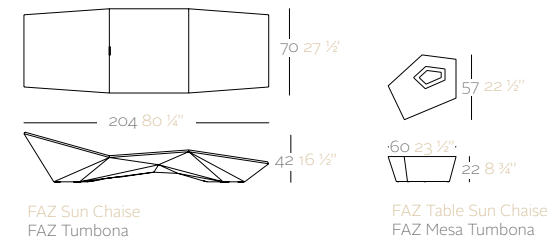
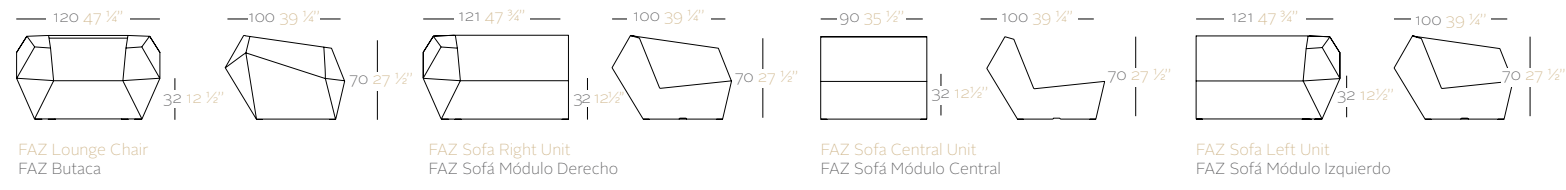

	Lounge Chair Butaca	Sofa Right Unit M. Dch	Sofa Central Unit M. Central	Sofa Left Unit M. Izq	Sun Chaise Tumbona	Table Sun Chaise Mesa Tumbona	Armchair Sillón
BASIC	54001 <sup>*t</sup>	54003 <sup>*te</sup>	54004 <sup>*te</sup>	54002 <sup>*te</sup>	54008 <sup>*</sup>	54009 <sup>t</sup>	54015 <sup>t</sup>
FOC	54001 <sup>F*t</sup>	54003 <sup>F*te</sup>	54004 <sup>F*te</sup>	54002 <sup>*te</sup>	54008 <sup>F*</sup>	54009 <sup>F<sup>t</sup></sup>	54015 <sup>F<sup>t</sup></sup>
LLUM	54001 <sup>W*ti</sup>	54003 <sup>W*tei</sup>	54004 <sup>W*tei</sup>	54002 <sup>W*tei</sup>	54008 <sup>W*ti</sup>	54009 <sup>W<sup>ti</sup></sup>	54015 <sup>W<sup>ti</sup></sup>
LED RGB	54001 <sup>L*ti</sup>	54003 <sup>L*tei</sup>	54004 <sup>L*tei</sup>	54002 <sup>L*tei</sup>	54008 <sup>L*ti</sup>	54009 <sup>L<sup>ti</sup></sup>	54015 <sup>L<sup>ti</sup></sup>
Cushion Acolchado	-	-	-	-	-	-	54015 <sup>C</sup>

Thick Cushion: 10 cm / 4" Grosor Acólchado: 10 cm  
Thick Cushion Armchair: 4 cm / 1 1/2" Grosor Acólchado Sillón: 4 cm

	Sofa Corner 90° M. Esquina 90°	Sofa Corner 45° M. Esquina 45°	Chaise Chaise	Table sofa Mesa sofá	Table 200 Mesa 200	Mesa 300
BASIC	53005 <sup>*te</sup>	53010 <sup>*te</sup>	53006 <sup>*t</sup>	53007	54016 <sup>t</sup>	54017 <sup>t</sup>
FOC	53005 <sup>F*te</sup>	53010 <sup>F*te</sup>	53006 <sup>F*t</sup>	53007 <sup>F<sup>t</sup></sup>	54016 <sup>F<sup>t</sup></sup>	54017 <sup>F<sup>t</sup></sup>
LLUM	53005 <sup>W*tei</sup>	53010 <sup>W*tei</sup>	53006 <sup>W*ti</sup>	53007 <sup>W<sup>ti</sup></sup>		-
LED RGB	53005 <sup>L*tei</sup>	53010 <sup>L*tei</sup>	53006 <sup>L*ti</sup>	53007 <sup>L<sup>ti</sup></sup>		-
FULL WHITE	-	-	-	-	54016B <sup>t</sup>	54017B <sup>t</sup>
FOC FULL WHITE	-	-	-	-	54016FB <sup>t</sup>	54017FB <sup>t</sup>
GLASS	-	-	-	-	54016G <sup>t</sup>	54017G <sup>t</sup>
FOC GLASS	-	-	-	-	54016FG <sup>t</sup>	54017FG <sup>t</sup>

\*\_ cushions are included in the prize.  
t\_ non-slipping feet included.  
e\_ joint set in order to fix them together.  
i\_ possibility of transparent cable & switch for indoor.

\*\_ acolchados incluidos en el precio.  
t\_ incluye tacos antideslizantes.  
e\_ incluye un set de ensamblaje para fijarlos entre ellos.  
i\_ posibilidad de cable transparente e interruptor para interior.

DIMENSIONS DIMENSIONES

FAZ MACETEROS XL designed by Ramon Esteve

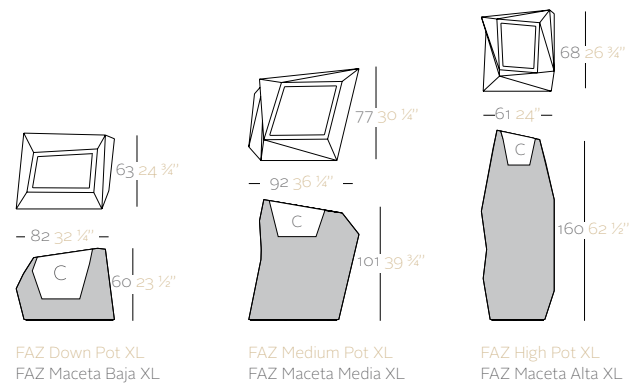

FAZ MACETEROS designed by Ramon Esteve

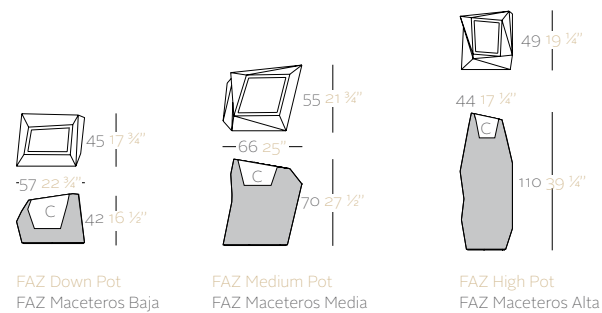

	L Gal	C (d X h) cm in	AIRE 🌀	AIGUA 💧	FOC 🏹	LLUM 🌙	LED RGB LED	Kit 4 Wheels Ruedas
Down Pot XL Macetero XL Baja	27 7	30 x 46 x 32 11 3/4" x 18" x 12 1/2"	54011A	54011R <sup>b</sup>	54011F <sup>b</sup>	54011W <sup>bi</sup>	54011L <sup>bi</sup>	53026
Medium Pot XL Maceteros XL Media	50 13	40 x 41 x 40 15 3/4" x 16 1/4" x 15 3/4"	54012A	54012R <sup>b</sup>	54012F <sup>b</sup>	54012W <sup>bi</sup>	54012L <sup>bi</sup>	53026
High Pot XL Maceteros XL Alta	29 7 1/2	37 x 27 x 40 14 1/2" x 10 3/4" x 15 3/4"	54013A	54013R <sup>b</sup>	54013F <sup>b</sup>	54013W <sup>bi</sup>	54013L <sup>bi</sup>	53026
Down Pot Macetero Baja	10 2 1/2	27,5 x 22 x 27 10 3/4" x 8 3/4" x 10 3/4"	54020A	54020R <sup>b</sup>	54020F <sup>b</sup>	54020W <sup>bi</sup>	54020L <sup>bi</sup>	53026
Medium Pot Macetero Media	21 5 1/2	31 x 30 x 31 16 1/2" x 11 3/4" x 16 1/4"	54021A	54021R <sup>b</sup>	54021F <sup>b</sup>	54021W <sup>bi</sup>	54021L <sup>bi</sup>	53026
High Pot Macetero Alta	10 2 1/2	28 x 21,5 x 27 11" x 8 1/2" x 10 3/4"	54022A	54022R <sup>b</sup>	54022F <sup>b</sup>	54022W <sup>bi</sup>	54022L <sup>bi</sup>	53026

b\_ self-watering included.

i\_ possibility of transparent cable & switch for indoor.

b\_ incluye sistema de autoriego.

i\_ posibilidad de cable transparente e interruptor para interior.

FAZ LÁMPARA designed by Ramon Esteve

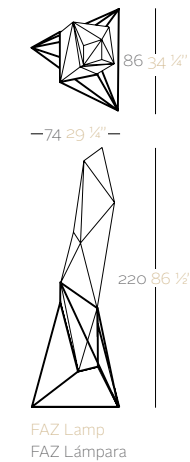

	LED LED	LED RGB LED
Lamp Lámpara	54018W <sup>i</sup>	54018L <sup>i</sup>

FAZ BANCO designed by Ramon Esteve

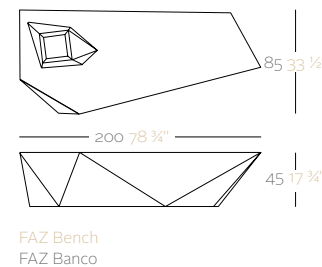

	BASIC B	AIGUA 💧	FOC 🏹	LLUM 🌙	LED RGB LED	Cushion Acolchado*	Kit Assembly Kit Union
Bench Banco	54046	54046R <sup>b</sup>	54046F <sup>b</sup>	54046W <sup>i</sup>	54046L <sup>i</sup>	54046C	54046X

\*Thick Cushion Bench: 4 cm / 1 1/2" Grosor Acolchado Banco: 4 cm

i\_ possibility of transparent cable & switch for indoor.

i\_ posibilidad de cable transparente e interruptor para interior.

# VELA COLLECTION

designed by Ramon Esteve

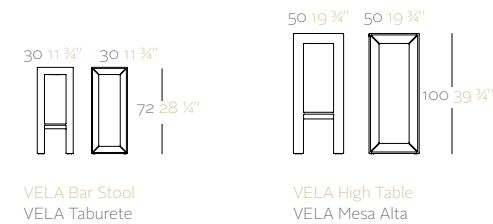
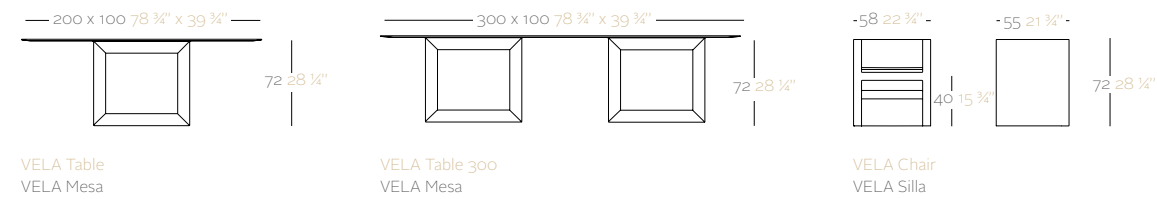
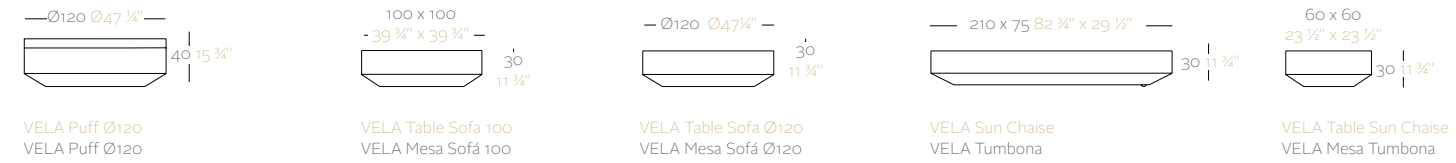
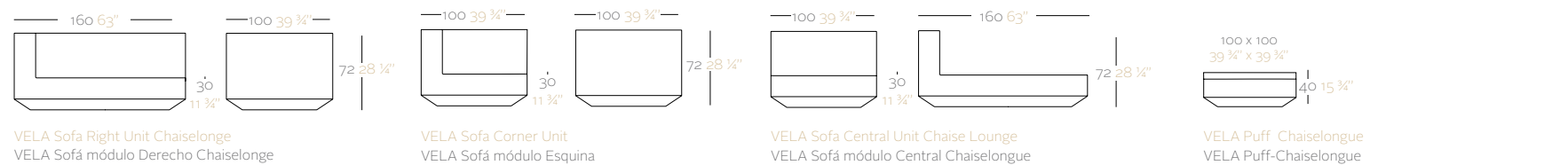
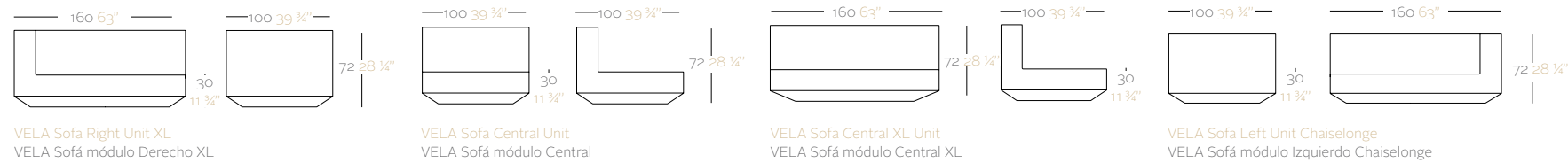
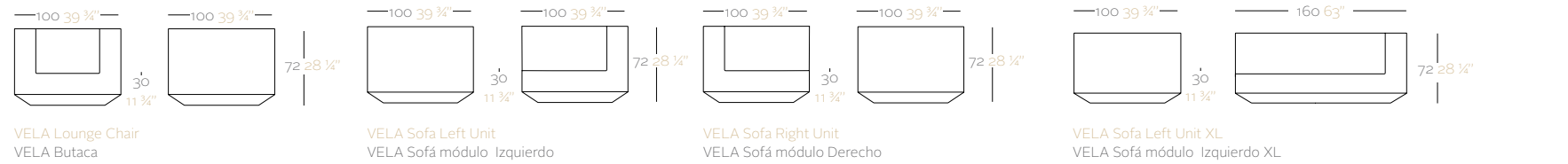

	Lounge Chair Butaca	Sofa Left Unit M. Izq	Sofa Right Unit M. Dch	Sofa Left Unit XL M. Izq XL	Sofa Right Unit XL M. Dch XL	Sofa Central Unit M. Central	Sofa Central XL Unit M. Central XL	Sofa Left Unit Chaiselonge M. Izq Chaiselonge	Sofa Right Unit Chaiselonge M. Dch Chaiselonge
BASIC	<b>B</b> 54023* <sup>t</sup>	54077* <sup>t</sup>	54078* <sup>t</sup>	54024* <sup>te</sup>	54025* <sup>te</sup>	54026* <sup>te</sup>	54027* <sup>te</sup>	54024* <sup>te</sup>	54025* <sup>te</sup>
FOC	<b>F</b> 54023F* <sup>t</sup>	54077F* <sup>t</sup>	54078F* <sup>t</sup>	54024F* <sup>te</sup>	54025F* <sup>te</sup>	54026F* <sup>te</sup>	54027F* <sup>te</sup>	54024F* <sup>te</sup>	54025F* <sup>te</sup>
LLUM	<b>L</b> 54023W* <sup>ti</sup>	54077W* <sup>ti</sup>	54078W* <sup>ti</sup>	54024W* <sup>tei</sup>	54025W* <sup>tei</sup>	54026W* <sup>tei</sup>	54027W* <sup>tei</sup>	54024W* <sup>tei</sup>	54025W* <sup>tei</sup>
LED RGB	<b>LED</b> 54023L* <sup>ti</sup>	54077L* <sup>ti</sup>	54078L* <sup>ti</sup>	54024L* <sup>tei</sup>	54025L* <sup>tei</sup>	54026L* <sup>tei</sup>	54027L* <sup>tei</sup>	54024L* <sup>tei</sup>	54025L* <sup>tei</sup>

	Sofa Corner Unit Sofá módulo Esquina	Sofa Central Unit Chaise M. Central Chaise	Puff Chaiselonge Puff Chaiselonge	Puff Ø120 Puff Ø120
BASIC	<b>B</b> 54029* <sup>te</sup>	54028* <sup>te</sup>	54032* <sup>te</sup>	54033* <sup>t</sup>
FOC	<b>F</b> 54029F* <sup>te</sup>	54028F* <sup>te</sup>	54032F* <sup>te</sup>	54033F* <sup>t</sup>
LLUM	<b>L</b> 54029W* <sup>tei</sup>	54028W* <sup>tei</sup>	54032W* <sup>tei</sup>	54033W* <sup>ti</sup>
LED RGB	<b>LED</b> 54029L* <sup>tei</sup>	54028L* <sup>tei</sup>	54032L* <sup>tei</sup>	54033L* <sup>ti</sup>

Thick Cushion: 10 cm / 4" Grosor Acolchado: 10 cm  
Thick Cushion Chair: 4 cm / 1 1/2" Grosor Acolchado Silla: 4 cm

	Table sofa 100 Mesa sofá 100	Table sofa Ø120 Mesa sofá Ø120	Sun Chaise Tumbona	Table Sun Chaise Mesa Tumbona	Table 200 Mesa 200	Table 300 Mesa 300	Chair Silla	Bar Stool Taburete	High Table Mesa Alta
BASIC	<b>B</b> 54030 <sup>t</sup>	54031 <sup>t</sup>	54034* <sup>am</sup>	54047 <sup>t</sup>	54050 <sup>t</sup>	54051 <sup>t</sup>	54052 <sup>t</sup>	54076 <sup>t</sup>	54075 <sup>t</sup>
FOC	<b>F</b> 54030F <sup>t</sup>	54031F <sup>t</sup>	54034F* <sup>am</sup>	54047F <sup>t</sup>	54050F <sup>t</sup>	54051F <sup>t</sup>	54052F* <sup>am</sup>	54076F	54075F
LLUM	<b>L</b> 54030W <sup>ti</sup>	54031W <sup>ti</sup>	54034W* <sup>ami</sup>	54047W <sup>ti</sup>	-	-	-	-	-
LED RGB	<b>LED</b> 54030L <sup>ti</sup>	54031L <sup>ti</sup>	54034L* <sup>ami</sup>	54047L <sup>ti</sup>	54050L <sup>ti</sup>	54051L <sup>ti</sup>	-	-	-
LED	-	-	-	-	54050W <sup>ti</sup>	54051W <sup>ti</sup>	-	-	-
Cushion Acolchado	-	-	-	-	-	-	54052C	-	-
Cover Table Polyethylene Cubre Mesa Polietileno	54030C	54031C	-	54047C	-	-	-	-	-
Cover Table Glass Cubre Mesa Glass	54030P	54031P	-	54047P	-	-	-	-	-

\*\_ cushions are included in the prize  
a\_ wheels included  
t\_ non-slipping feet included  
m\_ moving headrest  
e\_ join set in order to fix them together  
l\_ possibility of transparent cable & switch for indoor.

\*\_ acolchados incluidos en el precio  
a\_ incluye ruedas  
t\_ incluye tacos antideslizantes  
m\_ cabeza móvil  
e\_ incluye un set de ensamblaje para fijarlos entre ellos  
l\_ posibilidad de cable transparente e interruptor para interior.

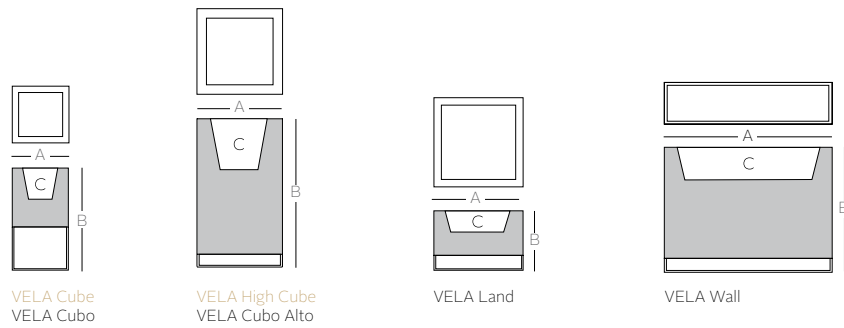

	A cm in	x	B cm in	L Gal	C (d X h) cm in	AIRE	AIGUA	FOC	LLUM	LED RGB <b>LED</b>
Cube 40 Cubo 40	40 x 40 15 3/4" x 15 3/4"	x	70 27 1/2"	22 6	31 x 31 x 31 12 1/2" x 12 1/2" x 12 1/2"	54035A	54035R <sup>b</sup>	54035F <sup>b</sup>	54035W <sup>bi</sup>	54035L <sup>bi</sup>
Cube 40 Cubo 60	60 x 60 23 1/2" x 23 1/2"	x	100 39 1/4"	72 19	46 x 46 x 46 18" x 18" x 18"	54042A	54042R <sup>b</sup>	54042F <sup>b</sup>	54042W <sup>bi</sup>	54042L <sup>bi</sup>
High Cube 40 Cubo Alto 40	40 x 40 15 3/4" x 15 3/4"	x	90 35 1/2"	24 6 1/2	30 x 30 x 33 11 3/4" x 11 3/4" x 13"	54049A	54049R <sup>b</sup>	54049F <sup>b</sup>	54049W <sup>bi</sup>	54049L <sup>bi</sup>
High Cube 60 Cubo Alto 60	60 x 60 23 1/2" x 23 1/2"	x	100 39 1/4"	72 19	46 x 46 x 46 18" x 18" x 18"	54036A	54036R <sup>b</sup>	54036F <sup>b</sup>	54036W <sup>bi</sup>	54036L <sup>bi</sup>
Land	60 x 60 23 1/2" x 23 1/2"	x	40 15 3/4"	30 8	46 x 46 x 24 18" x 18" x 9 1/2"	54037A	54037R <sup>b</sup>	54037F <sup>b</sup>	54037W <sup>bi</sup>	54037L <sup>bi</sup>
Wall	30 x 120 11 3/4" x 47 1/4"	x	90 35 1/2"	60 16	24 x 114 x 24 9 1/2" x 45" x 9 1/2"	54038A	54038R <sup>b</sup>	54038F <sup>b</sup>	54038W <sup>bi</sup>	54038L <sup>bi</sup>

	A cm in	x	B cm in	L Gal	C (d X h) cm in	NANO <b>nan</b>	NANO FOC <b>nan</b>	NANO LED <b>nan</b>
Nano Cube 28 Nano Cubo 28	18 x 18 7" x 7"	x	28 11"	2 1/2	14 x 14 x 12 5 1/2" x 5 1/2" x 4 3/4"	54043A	54043F	54043W
Nano Cube 36 Nano Cubo 36	18 x 18 7" x 7"	x	36 14 1/4"	2 1/2	14 x 14 x 12 5 1/2" x 5 1/2" x 4 3/4"	54039A	54039F	54039W
Nano High Cube 28 Nano Cubo Alto	18 x 18 7" x 7"	x	46 18"	1,5 1/2	14 x 14 x 23 5 1/2" x 5 1/2" x 9"	54040A	54040F	54040W

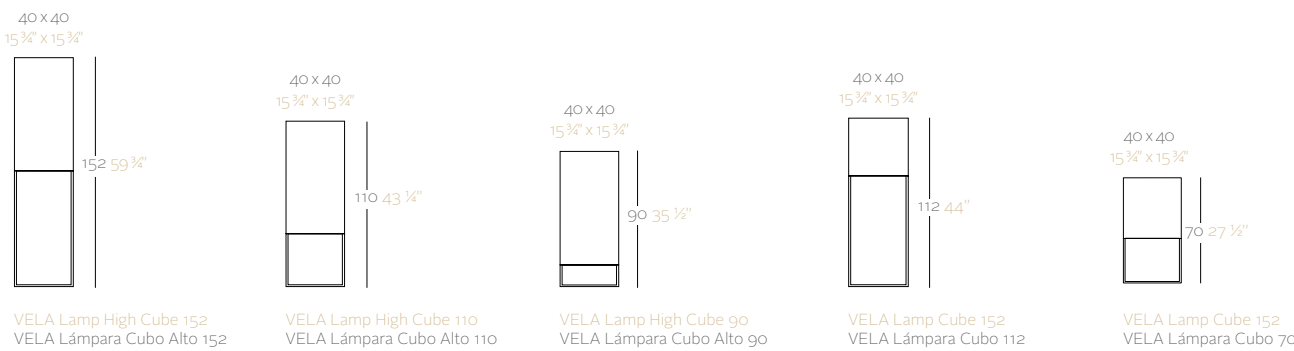

	LED <b>LED</b>	LED RGB <b>LED</b>
Lamp High Cube 152 Lámpara Cubo Alto 152	54068W <sup>i</sup>	54068L <sup>i</sup>
Lamp High Cube 110 Lámpara Cubo Alto 110	54067W <sup>i</sup>	54067L <sup>i</sup>
Lamp High Cube 90 Lámpara Cubo Alto 90	54066W <sup>i</sup>	54066L <sup>i</sup>
Lamp Cube 112 Lámpara Cubo 112	54065W <sup>i</sup>	54065L <sup>i</sup>
Lamp Cube 70 Lámpara Cubo 70	54064W <sup>i</sup>	54064L <sup>i</sup>

b\_ sell-watering included.  
 i\_ possibility of transparent cable & switch for indoor.  
 b\_ incluye sistema de autoriego.  
 i\_ posibilidad de cable transparente e interruptor para interior.

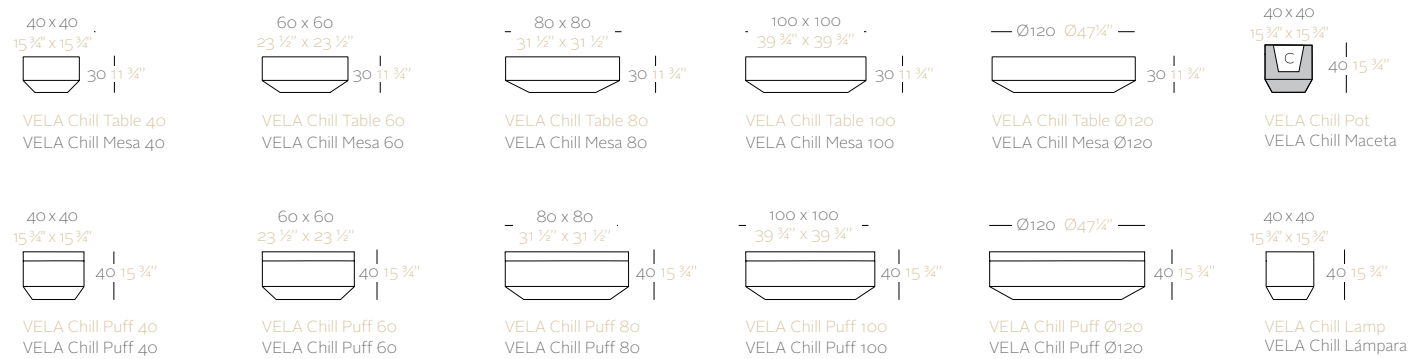

	L Gal	C (d X h) cm in	BASIC <b>B</b>	AIGUA	FOC	LLUM	LED RGB <b>LED</b>
Table 40 Mesa 40	-	-	54041 <sup>te</sup>	-	54041F <sup>*te</sup>	54041W <sup>*tei</sup>	54041L <sup>*tei</sup>
Table 60 Mesa 60	-	-	54047 <sup>te</sup>	-	54047F <sup>*te</sup>	54047W <sup>*tei</sup>	54047L <sup>*tei</sup>
Table 80 Mesa 80	-	-	54048 <sup>te</sup>	-	54048F <sup>*te</sup>	54048W <sup>*tei</sup>	54048L <sup>*tei</sup>
Table 100 Mesa 100	-	-	54030 <sup>te</sup>	-	54030F <sup>*te</sup>	54030W <sup>*tei</sup>	54030L <sup>*tei</sup>
Table Ø120 Mesa Ø120	-	-	54031 <sup>te</sup>	-	54031F <sup>*te</sup>	54031W <sup>*tei</sup>	54031L <sup>*tei</sup>
Cover Table Cubre Mesa GLASS 40	-	-	54041C	-	-	-	-
Cover Table Cubre Mesa PE 40	-	-	54041P	-	-	-	-
Cover Table Cubre Mesa GLASS 60	-	-	54047C	-	-	-	-
Cover Table Cubre Mesa PE 60	-	-	54047P	-	-	-	-
Cover Table Cubre Mesa GLASS 80	-	-	54048C	-	-	-	-
Cover Table Cubre Mesa PE 80	-	-	54048P	-	-	-	-
Cover Table Cubre Mesa GLASS 100	-	-	54030C	-	-	-	-
Cover Table Cubre Mesa PE 100	-	-	54030P	-	-	-	-
Cover Table Cubre Mesa GLASS Ø120	-	-	54031C	-	-	-	-
Cover Table Cubre Mesa PE Ø120	-	-	54031P	-	-	-	-
Pot Maceta	19 5	31 x 31 x 27 12 1/4" x 12 1/4" x 10 3/4"	-	54073R <sup>b</sup>	54073F <sup>b</sup>	54073W <sup>bi</sup>	54073L <sup>bi</sup>
Puff 40 Puff 40	-	-	54069 <sup>*te</sup>	-	54069F <sup>*te</sup>	54069W <sup>*tei</sup>	54069L <sup>*tei</sup>
Puff 60 Puff 60	-	-	54070 <sup>*te</sup>	-	54070F <sup>*te</sup>	54070W <sup>*tei</sup>	54070L <sup>*tei</sup>
Puff 80 Puff 80	-	-	54071 <sup>*te</sup>	-	54071F <sup>*te</sup>	54071W <sup>*tei</sup>	54071L <sup>*tei</sup>
Puff 100 Puff 100	-	-	54032 <sup>*te</sup>	-	54032F <sup>*te</sup>	54032W <sup>*tei</sup>	54032L <sup>*tei</sup>
Puff Ø120 Puff Ø120	-	-	54033 <sup>*te</sup>	-	54033F <sup>*te</sup>	54033W <sup>*tei</sup>	54033L <sup>*tei</sup>
Lamp Lámpara	-	-	-	-	-	54072W <sup>*tei</sup>	54072L <sup>*tei</sup>

Thick Cushion: 10 cm / 4" Grosor Acollchado: 10 cm

b\_ sell-watering included.  
 \*\_ cushions are included in the prize  
 t\_ non-slipping feet included  
 e\_ join set in order to fix them together  
 i\_ possibility of transparent cable & switch for indoor

b\_ incluye sistema de autoriego  
 \*\_ acolchados incluidos en el precio  
 t\_ incluye tacos antideslizantes  
 e\_ incluye un set de ensamblaje para fijarlos entre ellos  
 i\_ posibilidad de cable transparente e interruptor para interior

# VELA COLLECTION

designed by Ramon Esteve

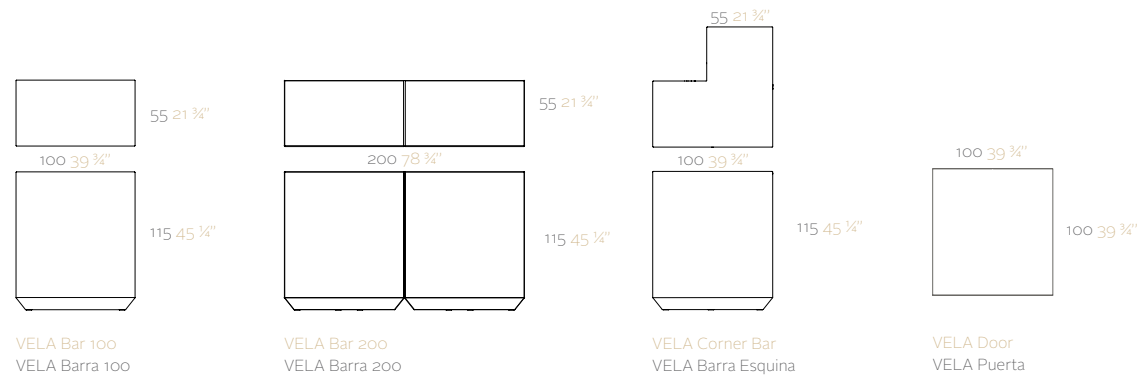

	BASIC <b>B</b>	FOC <b>F</b>	LLUM <b>L</b>	LED RGB <b>LED</b>	SET 2 Shelves SET 2 Estantes	Inox Cover Cubre Inox	Glass Cover Cubre Glass	Set 8 Wheels SET 8 Ruedas
Bar 100 Barra 100	54081	54081F	54081W <sup>l</sup>	54081L <sup>l</sup>	54081E	54081X	54081C	54081B
Bar 200 Barra 200	54082	54082F	54082W <sup>l</sup>	54082L <sup>l</sup>	54082E	54082X	54082C	54082B
Corner Bar Barra Esquina	54083	54083F	54083W <sup>l</sup>	54083L <sup>l</sup>	54083E	54083X	54083C	54083B
Door Puerta	54084	54084F	-	-	-	-	-	-

# STONE COLLECTION

designed by Stefano Giovannoni

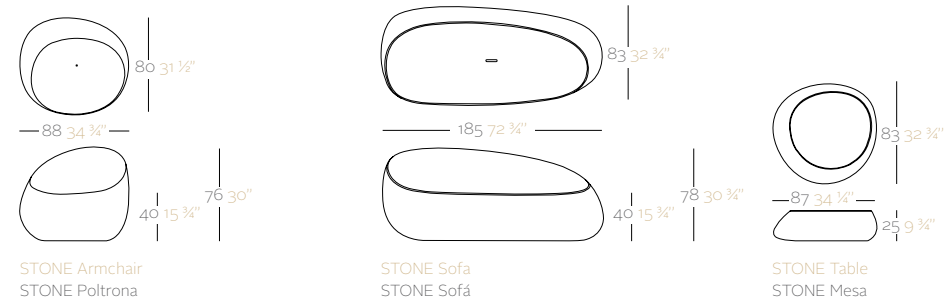

	BASIC <b>B</b>	FOC <b>F</b>	LLUM <b>L</b>	LED RGB <b>LED</b>
Armchair Poltrona	55005	55005F <sup>b</sup>	55005W <sup>bi</sup>	55005L <sup>bi</sup>
Sofa Sofá	55006	55006F <sup>b</sup>	55006W <sup>bi</sup>	55006L <sup>bi</sup>
Table Mesa	55007	55007F <sup>b</sup>	55007W <sup>bi</sup>	55007L <sup>bi</sup>

# PILLOW COLLECTION

designed by Stefano Giovannoni

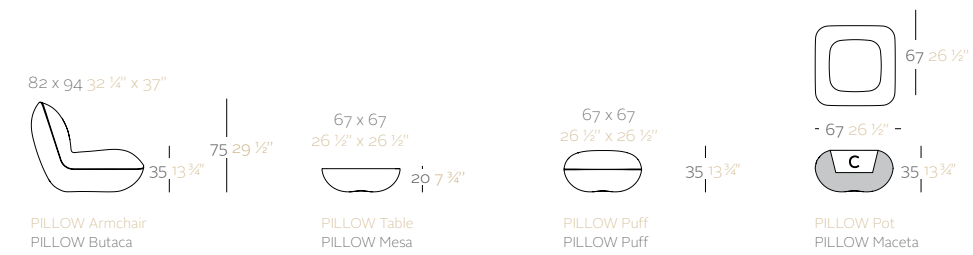

	L Gal	C (d X h) cm in	BASIC <b>B</b>	AIGUA <b>A</b>	FOC <b>F</b>	LLUM <b>L</b>	LED RGB <b>LED</b>
Armchair Butaca	-	-	55001	-	55001F	55001W <sup>l</sup>	55001L <sup>l</sup>
Table Mesa	-	-	55002	-	55002F	55002W <sup>l</sup>	55002L <sup>l</sup>
Puff Puff	-	-	55003	-	55003F	55003W <sup>l</sup>	55003L <sup>l</sup>
Pot Maceta	24 6 ½	21 x 24 8 ½" x 9 ½"	55004	55004R <sup>b</sup>	55004F <sup>b</sup>	54020W <sup>bi</sup>	55004L <sup>ib</sup>

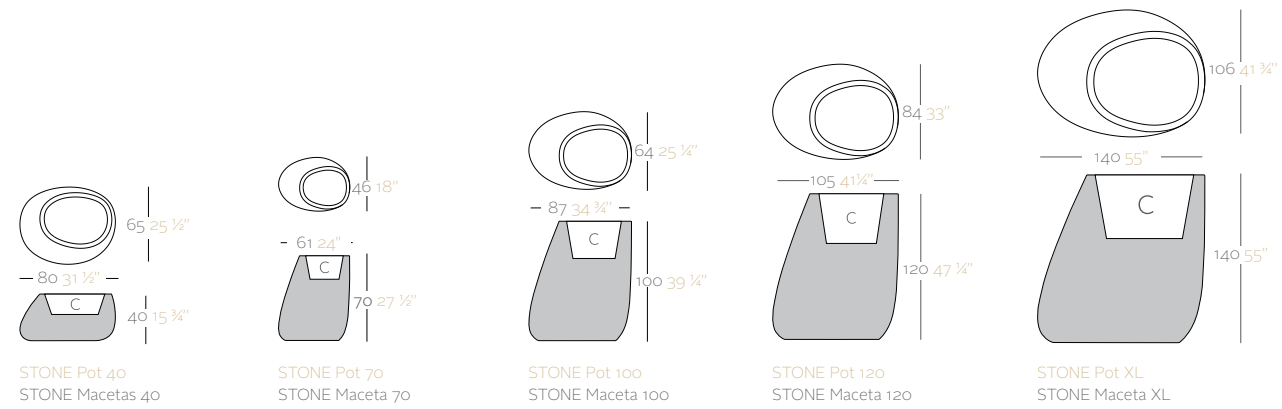

	L Gal	C (d X h) cm in	AIRE <b>A</b>	AIGUA <b>A</b>	FOC <b>F</b>	LLUM <b>L</b>	LED RGB <b>LED</b>
Pot 40 Maceta 40	32 8 ½	52 x 39 x 26 20 ½" x 15 ¼" x 10 ¼"	55008	55008R <sup>b</sup>	55008F <sup>b</sup>	55008W <sup>bi</sup>	55008L <sup>bi</sup>
Pot 70 Maceta 70	20 5 ½	37 x 29 x 28 14 ½" x 11 ½" x 10 ¼"	55009	55009R <sup>b</sup>	55009F <sup>b</sup>	55009W <sup>bi</sup>	55009L <sup>bi</sup>
Pot 100 Maceta 100	52 13 ½	54 x 44 x 39 21 ¼" x 15 ¼" x 15 ¼"	55010	55010R <sup>b</sup>	55010F <sup>b</sup>	55010W <sup>bi</sup>	55010L <sup>bi</sup>
Pot 120 Maceta 120	105 27 ½	65 x 56 x 46 25 ½" x 22" x 18"	55011	55011R <sup>b</sup>	55011F <sup>b</sup>	55011W <sup>bi</sup>	55011L <sup>bi</sup>
Pot XL Maceta XL	252 66 ½	90 x 72 x 62 35 ½" x 28 ¼" x 24 ½"	55012	55012R <sup>b</sup>	55012F <sup>b</sup>	55012W <sup>bi</sup>	55012L <sup>bi</sup>

b\_ sell-watering included.  
 l\_ possibility of transparent cable & switch for indoor.  
 b\_ incluye sistema de autoriego.  
 l\_ posibilidad de cable transparente e interruptor para interior.

# VASES COLLECTION

designed by JMFerrero

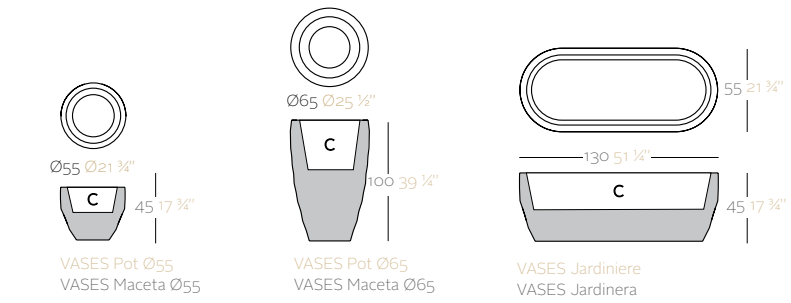

	L Gal	C (d X h) cm in	AIRE	AIGUA	FOC	LLUM	LED RGB
VASES Ø55	41 11	Ø46 x 30 Ø18" x 11 ¾"	47055A	47055R <sup>b</sup>	47055F <sup>b</sup>	47055W <sup>bi</sup>	47055L <sup>bi</sup>
VASES Ø65	56 15	Ø50 x 39 Ø19 ¾" x 15 ¼"	47065A	47065R <sup>b</sup>	47065F <sup>b</sup>	47065W <sup>bi</sup>	47065L <sup>bi</sup>
VASES Jardiniere VASES Jardinera	128 34	120 x 46 x 39 47 ¼" x 18" x 15 ¼"	47130A	47130R <sup>b</sup>	47130F <sup>b</sup>	47130W <sup>bi</sup>	47130L <sup>bi</sup>

	A cm in	x	B cm in	L Gal	C (d X h) cm in	NANO	NANO FOC	NANO LED
Nano Vases Ø14 x 12	Ø14 Ø5 ½"	x	12 4 ¾"	0,5 1/4	Ø11 x 8 Ø4 ¼" x 3 ¼"	47012A	47012F	47012W
Nano Vases Ø14 x 28	Ø14 Ø5 ½"	x	28 11"	1 1/2	Ø11 x 15 Ø4 ¼" x 6"	47028A	47028F	47028W
Nano Vases Ø18 x 15	Ø18 Ø7"	x	15 6"	1 1/2	Ø14 x 11 Ø5 ½" x 4 ¼"	47018A	47018F	47018W
Nano Vases Ø18 x 36	Ø18 Ø7"	x	36 14 ¼"	2 1/2	Ø18 x 18 Ø7" x 7"	47036A	47036F	47036W
Nano Jardiniere Nano Jardinera	14 x 33 5 ½" x 13"	x	12 4 ¾"	2,5 3/4	11 x 31 x 9 4 ¼" x 12 ¼" x 3 ½"	47033A	47033F	47033W

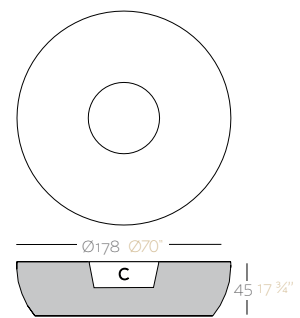

VASES Island  
VASES Isla

	L Gal	C (d X h) cm in	AIRE	AIGUA	FOC	LLUM	LED RGB	Cushion Acolchado
Island Isla	103 27 1/4	Ø69 x 39 Ø27 ¼" x 5 ¾"	47178A	47178R <sup>b</sup>	47178F <sup>b</sup>	47178W <sup>bi</sup>	47178L <sup>bi</sup>	44578

Thick Cushion Isla: 4 cm / 1 ½" Grosor Acollchado Isla: 4 cm

b\_ sell-watering included.  
 l\_ possibility of transparent cable & switch for indoor.  
 b\_ incluye sistema de autoriego.  
 l\_ posibilidad de cable transparente e interruptor para interior.

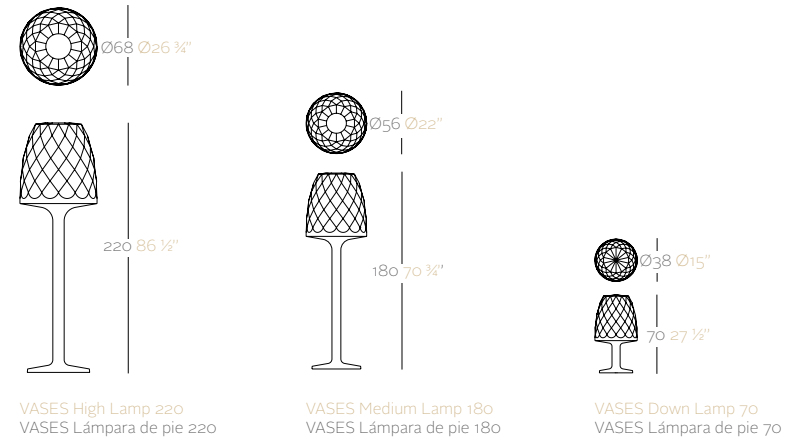

	LLUM	LED RGB
High Lamp 220 Lámpara de pie 220	47068W <sup>i</sup>	47068L <sup>i</sup>
Medium Lamp 180 Lámpara de pie 180	47056W <sup>i</sup>	47056L <sup>i</sup>
Down Lamp 70 Lámpara de pie 70	47038W <sup>i</sup>	47038L <sup>i</sup>

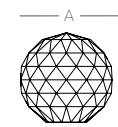

VASES Lamp  
VASES Bola lámpara

A cm in	Kit Ceiling Holder Colgante	LLUM	LED RGB
Ø30 Ø11 ¾"	48000X	48030W <sup>i</sup>	48030L <sup>i</sup>
Ø40 Ø15 ¾"	48000X	48040W <sup>i</sup>	48030L <sup>i</sup>
Ø60 Ø23 ½"	48000X	48060W <sup>i</sup>	48030L <sup>i</sup>

i\_ possibility of transparent cable & switch for indoor.  
 l\_ posibilidad de cable transparente e interruptor para interior.

# CHEMISTUBES COLLECTION

designed by Teresa Sapey

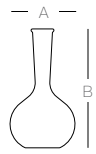

	A cm in	x	B cm in	L Gal	AIRE	FOC	LLUM	LED RGB
Flask 65	Ø36 Ø14 ¼"	x	65 25 ½"	5 1½	49036A	49036F	49036W <sup>i</sup>	49036L <sup>i</sup>
Flask 100	Ø55 Ø21 ¾"	x	100 39 ¼"	5 1½	49055A	49055F	49055W <sup>i</sup>	49055L <sup>i</sup>

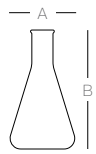

	A cm in	x	B cm in	L Gal	AIRE	FOC	LLUM	LED RGB
Erlenmeyer 65	Ø36 Ø14 ¼"	x	65 25 ½"	1,5 1/2	49058A	49058F	49058W <sup>i</sup>	49058L <sup>i</sup>
Erlenmeyer 100	Ø55 Ø21 ¾"	x	100 39 ¼"	4 1	49059A	49059F	49059W <sup>i</sup>	49059L <sup>i</sup>

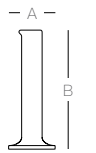

	A cm in	x	B cm in	L Gal	AIRE	FOC	LLUM	LED RGB
Pipe 65	Ø30 Ø11 ¾"	x	65 25 ½"	1,5 1/2	49056A	49056F	49056W <sup>i</sup>	49056L <sup>i</sup>
Pipe 100	Ø40 Ø15 ¾"	x	100 39 ¼"	3,5 1	49057A	49057F	49057W <sup>i</sup>	49057L <sup>i</sup>

b\_ self-watering included.  
 i\_ possibility of transparent cable & switch for indoor.  
 b\_ incluye sistema de autoriego.  
 i\_ posibilidad de cable transparente e interruptor para interior.

# FIESTA COLLECTION

designed by Archirivolto Design

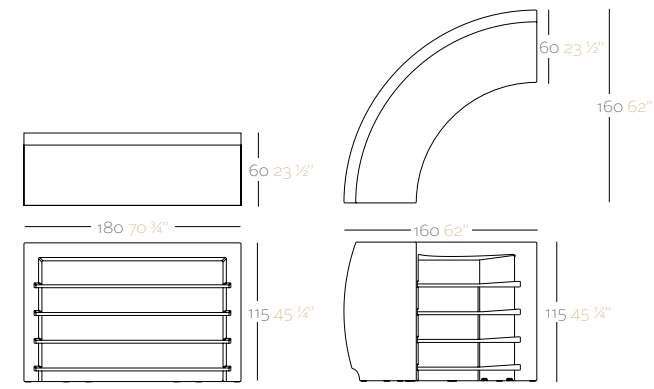

FIESTA Bar  
FIESTA Barra

FIESTA Curve Bar  
FIESTA Barra Curva

	BASIC	FOC	LLUM	LED RGB	SET 2 Shelves SET 2 Estantes	Inox Cover Cubre Inox	Glass Cover Cubre Glass	Set 8 Wheels SET 8 Ruedas
Bar Barra	56001	56001F	56001W <sup>i</sup>	56001L <sup>i</sup>	56001E	56001X	56001C	56001B
Curve Bar Barra Curva	56002	56002F	56002W <sup>i</sup>	56002L <sup>i</sup>	56002E	56002X	56002C	56002B

# BONES COLLECTION

designed by Ludovica + Roberto Palomba

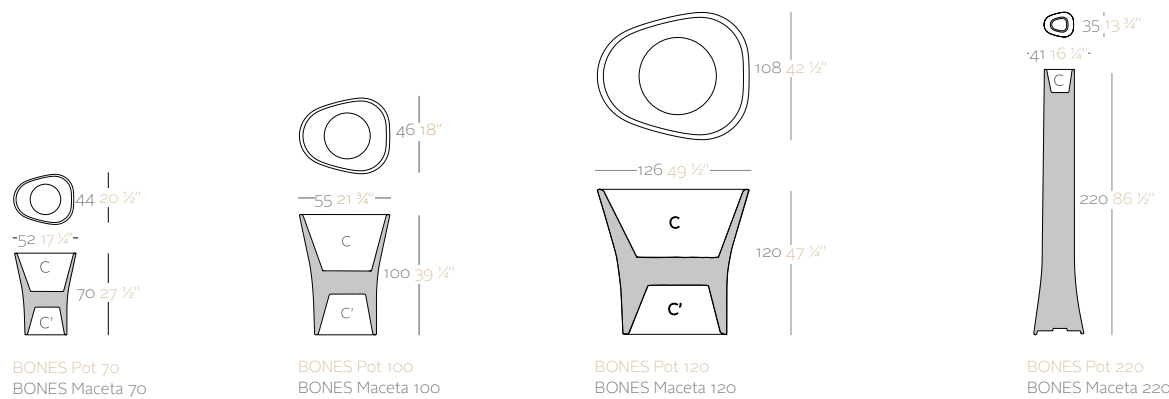

	L Gal	L' Gal	C (d X h) cm in	C' (d X h) cm in	AIRE	AIGUA	FOC	LLUM	LED RGB
Pot 70 Maceta 70	29 7 3/4	10 2 3/4	Ø38 x 28 Ø35" x 11"	Ø25 x 20 Ø9 3/4" x 9 3/4"	57002A	57002R <sup>b</sup>	57002F <sup>b</sup>	57002W <sup>bi</sup>	57002L <sup>bi</sup>
Pot 100 Maceta 100	30,5 8	14 3 3/4	Ø39 x 28 Ø39 1/2" x 11"	Ø25 x 28 Ø9 3/4" x 11"	57003A	57003R <sup>b</sup>	57003F <sup>b</sup>	57003W <sup>bi</sup>	57003L <sup>bi</sup>
Pot 120 Maceta 120	452 119	143 37 3/4	Ø104 x 63 Ø41" x 24 3/4"	Ø70 x 46 Ø27 1/2" x 18"	57004A	57004R <sup>b</sup>	57004F <sup>b</sup>	57004W <sup>bi</sup>	57004L <sup>bi</sup>
Pot 220 Maceta 220	4 1	-	Ø17 x 19 Ø6 3/4" x 7 1/2"	-	57001A	-	57001F <sup>b</sup>	57001W <sup>bi</sup>	57001L <sup>bi</sup>

# BYE-BYE COLLECTION

designed by Harry&Camila

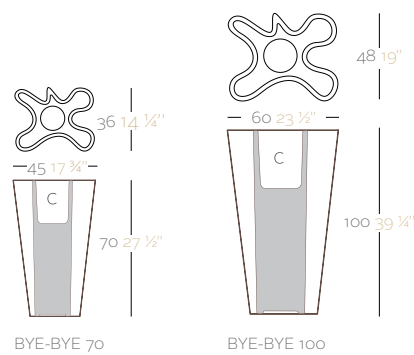

	L Gal	C (d X h) cm	AIRE	AIGUA	FOC	LLUM	LED RGB
Pot 70 Maceta 70	10 2 3/4	Ø18 x 24 Ø7" x 9 1/2"	58003A	58003R <sup>b</sup>	58003F <sup>b</sup>	58003W <sup>bi</sup>	58003L <sup>bi</sup>
Pot 100 Maceta 100	15 4	Ø25 x 30 Ø9 3/4" x 11 3/4"	58004A	58004R <sup>b</sup>	58004F <sup>b</sup>	58004W <sup>bi</sup>	58004L <sup>bi</sup>

b\_sell-watering included.  
 i\_ possibility of transparent cable & switch for indoor.  
 b\_incluye sistema de autoriego.  
 i\_posibilidad de cable transparente e interruptor para interior.

# Accessories Accessories



Square Pillow  
Cojín Rectangular

	A x B cm in	Ref.
Lounge Chair Butaca	Ø15 x 58 Ø5" x 22 3/4"	53015
Unit Modulo	Ø15 x 90 Ø5" x 35"	53017
Corner Esquina	Ø15 x 50 Ø5" x 19 3/4"	53019



Cushion Colors  
Colores Acollchado



Cilindric Pillow  
Cojín Cilindrico

	A x B cm in	Ref.
Lounge Chair Butaca	Ø15 x 58 Ø5" x 22 3/4"	53014
Unit Modulo	Ø15 x 90 Ø5" x 35"	53016
Corner Esquina	Ø15 x 50 Ø5" x 19 3/4"	53018



Cushion Colors  
Colores Acollchado



Pillow  
Cojín

	A x B cm in	Ref.
Pillow 40 Cojín 40	40 x 40 x 15 15 3/4" x 15 3/4" x 6"	53020
Pillow 50 Cojín 50	50 x 50 x 15 19 3/4" x 19 3/4" x 6"	53025
Pillow 50 Cojín 50	50 x 35 x 15 19 3/4" x 13 3/4" x 6"	53023
Pillow 60 Cojín 60	60 x 60 x 15 23 1/2" x 23 1/2" x 6"	53024



Cushion Colors  
Colores Acollchado



Kubico - marble cubes  
Kubico - dados de mármol

	Saco 15 kg Bag 33 lb	BIG-BAG 1000 Kg BIG-BAG 2204 lb
White Blanco	43201	43203
Black Negro	43202	43204



Kubico Colors  
Colores Kubico

Note: All dimensions shown in this catalogue are in centimetres and inches, litres and gallon, kilograms and pounds.

Nota: Todas las dimensiones que aparecen en este catálogo están en centímetros y pulgadas, litros y galones, kilos y libras.

Art Director	Ramon Esteve
Design	Ramon Esteve Studio Vondom
Photo	Eduardo Peris Enric Rodríguez Pedro Galisteo Jonathan Segade
Architecture	Ramon Esteve A-cero

CVD\_0212

Special Edition II Saloni 2012

Edición Especial II Saloni 2012

The possible differences can be due to the colors is the print technology.

VONDOM all rights related to trademarks, pictures and designs used in the collection are reserved.

All manufacturing, distribution and/or trading activities in any media of the products present in the collections are prohibited. Specifically, and/or use out of the privative use and with commercial purposes are reserved to the order of their owner.

VONDOM reserves the right to effect any changes or improvements, without notice.

All the information included in this catalogue regarding measurements and capacities are approximated.

All rights reserved to the order of VONDOM.

Las posibles diferencias entre el color original y el color reproducido se deben a la técnica de impresión.

VONDOM se reserva el derecho exclusivo sobre todas las marcas, fotografías y diseños utilizados en sus colecciones, por lo que queda prohibida la fabricación, distribución y/o comercialización de los productos que los contienen, en cualquier medio o soporte.

En particular quedan reservados a favor de su titular los derechos de reproducción total o parcial, la transformación de los mismos y/o su utilización fuera de la esfera privada y con fines comerciales.

VONDOM se reserva el derecho de modificar total o parcialmente sin aviso previo cualquiera de los datos y especificaciones de esta publicación.

Toda la información que aparece en este catálogo referente a dimensiones y capacidades son aproximadas.

Todos los derechos a beneficio de VONDOM.

**INNOEMPRESA**

**IMPIVA**

**UNIÓN EUROPEA**  
Fondos Europeos de Desarrollo Regional

Una manera de hacer Europa



**VONDOM®**

VONDOM S.L.U.

Avda. Valencia 3 - 46891 - El Palomar - Valencia - Spain

t. +34 96 239 84 86 - f. +34 96 290 05 01

info@vondom.com - www.vohdom.com

**VONDOM®**